

HEATHKIT[®] MANUAL

for the
**SINGLE SIDEBAND
TRANSCEIVER**
Model SB-104A
Operation 595-1994-06

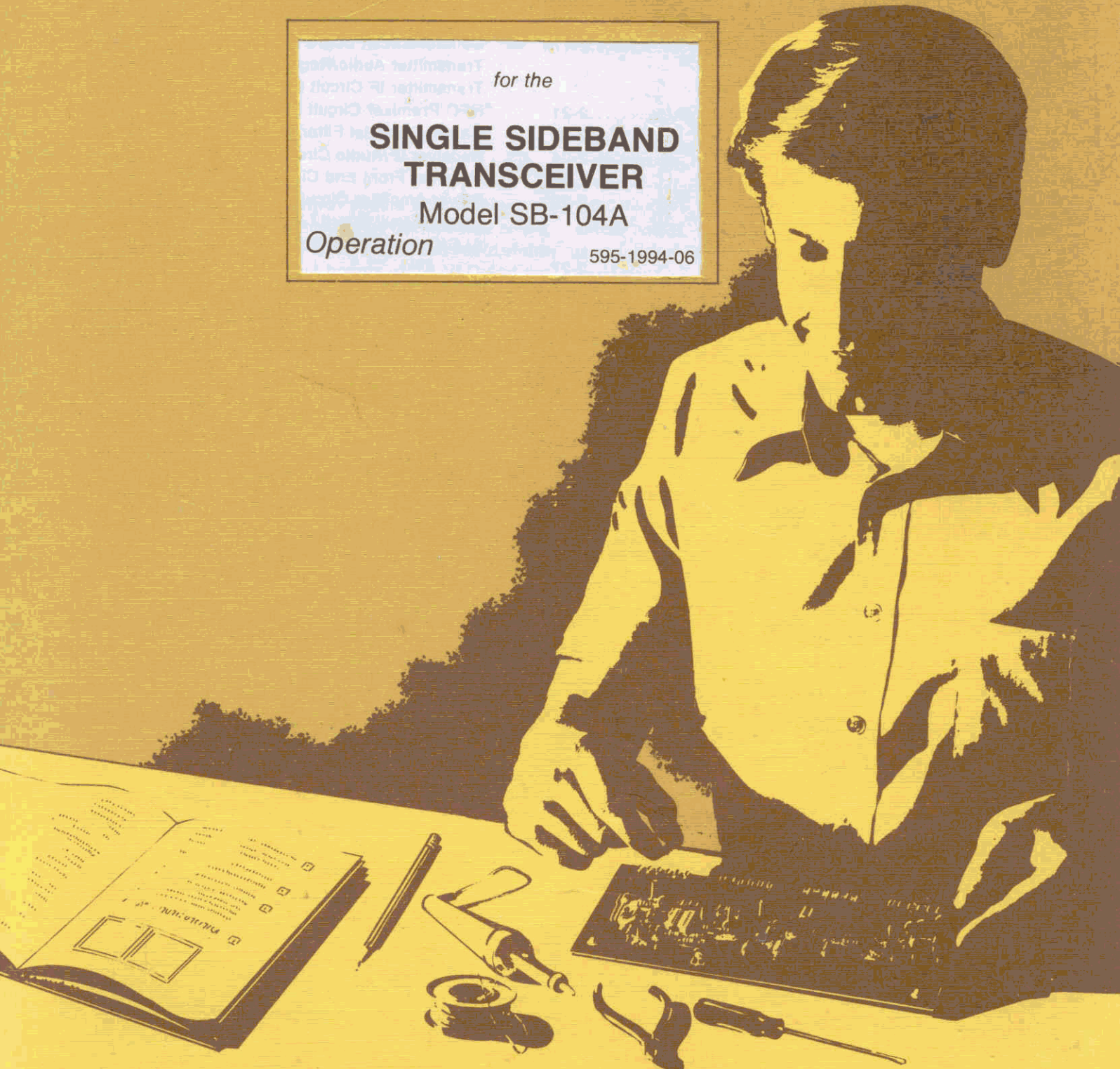

HEATH COMPANY • BENTON HARBOR, MICHIGAN

HEATH COMPANY PHONE DIRECTORY

The following telephone numbers are direct lines to the departments listed:

Kit orders and delivery information (616) 982-3411
Credit (616) 982-3561
Replacement Parts (616) 982-3571

Technical Assistance Phone Numbers

8:00 A.M. to 12 P.M. and 1:00 P.M. to 4:30 P.M., EST, Weekdays Only
R/C, Audio, and Electronic Organs (616) 982-3310
Amateur Radio (616) 982-3296
Test Equipment, Weather Instruments and
Home Clocks (616) 982-3315
Television (616) 982-3307
Aircraft, Marine, Security, Scanners, Automotive,
Appliances and General Products (616) 982-3496
Computers — Hardware (616) 982-3309
Computers — Software:
Operating Systems, Languages, Utilities (616) 982-3860
Application Programs (616) 982-3884
Heath Craft Wood Works (616) 982-3423

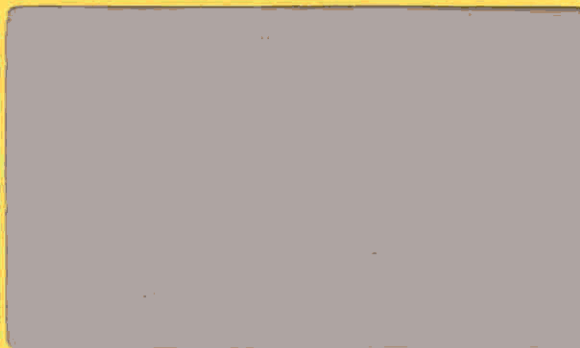

YOUR HEATHKIT 90-DAY LIMITED WARRANTY

Consumer Protection Plan for Heathkit Consumer Products

Welcome to the Heath family. We believe you will enjoy assembling your kit and will be pleased with its performance. Please read this Consumer Protection Plan carefully. It is a "LIMITED WARRANTY" as defined in the U.S. Consumer Product Warranty and Federal Trade Commission Improvement Act. This warranty gives you specific legal rights, and you may also have other rights which vary from state to state.

Heath's Responsibility

PARTS — Replacements for factory defective parts will be supplied free for 90 days from date of purchase. Replacement parts are warranted for the remaining portion of the original warranty period. You can obtain warranty parts direct from Heath Company by writing or telephoning us at (616) 982-3571. And we will pay shipping charges to get those parts to you . . . anywhere in the world.

SERVICE LABOR — For a period of 90 days from the date of purchase, any malfunction caused by defective parts or error in design will be corrected at no charge to you. You must deliver the unit at your expense to the Heath factory, any Heathkit Electronic Center (units of Veritechnology Electronics Corporation), or any of our authorized overseas distributors.

TECHNICAL CONSULTATION — You will receive free consultation on any problem you might encounter in the assembly or use of your Heathkit product. Just drop us a line or give us a call. Sorry, we cannot accept collect calls.

NOT COVERED — The correction of assembly errors, adjustments, calibration, and damage due to misuse, abuse, or negligence are not covered by the warranty. Use of corrosive solder and/or the unauthorized modification of the product or of any furnished component will void this warranty in its entirety. This warranty does not include reimbursement for inconvenience, loss of use, customer assembly, set-up time, or unauthorized service.

This warranty covers only Heath products and is not extended to other equipment or components that a customer uses in conjunction with our products.

SUCH REPAIR AND REPLACEMENT SHALL BE THE SOLE REMEDY OF THE CUSTOMER AND THERE SHALL BE NO LIABILITY ON THE PART OF HEATH FOR ANY SPECIAL, INDIRECT, INCIDENTAL OR CONSEQUENTIAL DAMAGES, INCLUDING BUT NOT LIMITED TO ANY LOSS OF BUSINESS OR PROFITS, WHETHER OR NOT FORSEEABLE.

Some states do not allow the exclusion or limitation of incidental or consequential damages, so the above limitation or exclusion may not apply to you.

Owner's Responsibility

EFFECTIVE WARRANTY DATE — Warranty begins on the date of first consumer purchase. You must supply a copy of your proof of purchase when you request warranty service or parts.

ASSEMBLY — Before seeking warranty service, you should complete the assembly by carefully following the manual instructions. Heathkit service agencies cannot complete assembly and adjustments that are customer's responsibility.

ACCESSORY EQUIPMENT — Performance malfunctions involving other non-Heath accessory equipment, (antennas, audio components, computer peripherals and software, etc.) are not covered by this warranty and are the owner's responsibility.

SHIPPING UNITS — Follow the packing instructions published in the assembly manuals. Damage due to inadequate packing cannot be repaired under warranty.

If you are not satisfied with our service (warranty or otherwise) or our products, write directly to our Director of Customer Service, Heath Company, Benton Harbor MI 49022. He will make certain your problems receive immediate, personal attention.

Heathkit® Manual

for the

SINGLE SIDEBAND TRANSCEIVER

Model SB-104A

Operation

595-1994-06

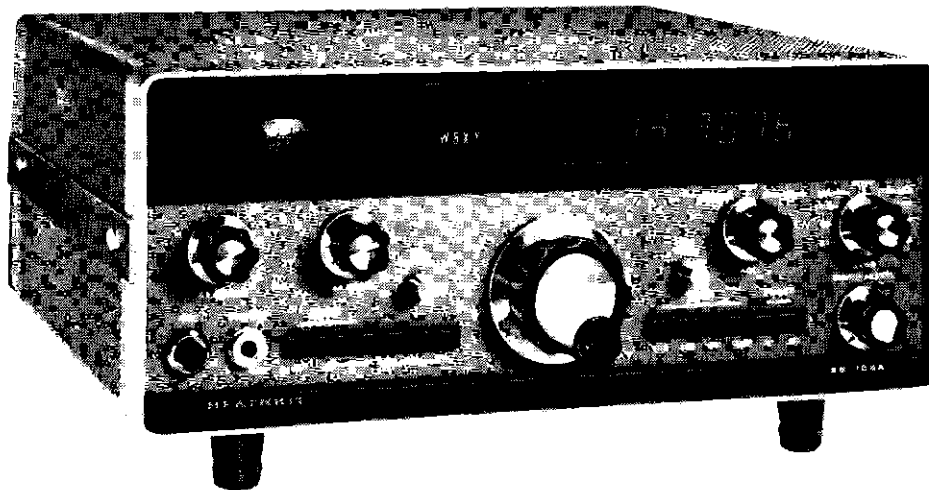

HEATH COMPANY
BENTON HARBOR, MICHIGAN 49022

Copyright © 1977
Heath Company
All Rights Reserved
Printed in the United States of America

TABLE OF CONTENTS

TEST AND ADJUSTMENTS	2-3	Circuit Board Service Policy	2-45
FINAL ASSEMBLY	2-15	VFO and Buffer Circuit Boards	2-47
INSTALLATION		VFO Filter Circuit Board	2-50
Fixed Station Installation	2-17	Converter Circuit Board	2-52
OPERATION		Display Circuit Board	2-54
Control Functions	2-21	Counter Circuit Board (A)	2-57
Tune-up	2-23	Transmitter Audio/Reg Circuit Board (B)	2-62
Receiving	2-24	Transmitter IF Circuit Board (C)	2-67
Transmitting	2-25	HFO/Premixer Circuit Board (D)	2-74
Typical Operating Characteristics	2-26	Carrier Gen/Xtal Filter Circuit Board (E)	2-79
TROUBLESHOOTING		Receiver IF/Audio Circuit Board (F)	2-84
Introduction	2-27	Receiver Front End Circuit Board (G)	2-89
Localizing the Trouble	2-28	Power Amplifier Circuit Board (H)	2-98
VFO/Buffer Troubleshooting Guide	2-28	Driver Circuit Board (J)	2-102
Receiver Troubleshooting Guide	2-30	ALC/Output Circuit Board (K)	2-104
Transmitter Troubleshooting Guide	2-32	SPECIFICATIONS	2-107
Display Troubleshooting Guide	2-34	THEORY OF OPERATION	2-111
Voltage and Continuity Checks	2-36	CHASSIS PHOTOGRAPHS	2-113
Test Chart	2-37	SCHEMATIC	(fold-in)
Checking Transistors and Diodes	2-38	WARRANTY	Inside front cover
MAINTENANCE	2-39	CUSTOMER SERVICE	Inside rear cover
Pin-out Diagrams	2-40		
Identification Charts	2-43		

TEST AND ADJUSTMENTS

The only circuit boards which should be connected or installed at this time are: the display circuit board on the back of the front panel, the VFO/Filter circuit board under the chassis, and the circuit boards in the VFO and the Converter assemblies. The remaining circuit boards will be installed as part of this "Test and Adjustments" section.

If you do not obtain the expected results after you insert each circuit board, refer to the boxed "Possible Cause Chart" which follows. If none of the difficulties listed is the cause of the malfunction, refer to the appropriate parts of the "Troubleshooting" and "Maintenance" sections. If you have a difficulty, DO NOT proceed until it has been corrected as, in some cases, damage could result.

A push-to-talk switch, as found on most microphones, is a convenient way to key the transmitter in the following steps. If your microphone cord is not already wired to an Amphenol 80MC2M connector (furnished), you should refer to Figure 2-5 in the "Installation" section of this Manual for the necessary wiring diagram.

When a voltmeter is required, use a meter which has a high input impedance (one megohm or more).

Refer to Figure 1-1 for front panel locations and to Figure 1-2 for rear panel connections (Illustration Booklet, Page 1).

Refer to Figure 1-3 to identify circuit boards, controls not mounted on the chassis, and some adjustment locations.

If you have difficulty in removing a circuit board, use screwdrivers in the board pullers as shown in Figure 1-4 (Illustration Booklet, Page 2).

IMPORTANT: After you install any one of the plug-in circuit boards, carefully inspect both sides to be sure no circuit board component touches a metal shield, which could cause a short circuit.

PUSHBUTTON OPERATION

The pushbuttons on switches S2 and S3 operate in the following ways:

1. Push in to latch. Release by pushing again and quickly removing your finger. Example: the ON switch.
2. Push in to latch. Release by depressing another button in the same group. Example: the USB, LSB, CW group.
3. To release a depressed button in a group, gently push another button in the same group until the depressed button releases.

CHASSIS

- () Depress the 13.8 and the USB pushbuttons on the front panel. All other pushbuttons should be released (out).
- () Push the 11-pin socket on the power supply cable onto the PWR plug on the rear panel of the Transceiver. Make sure the keyway in the socket mates with the key on the plug.
- () Connect the power supply to the proper AC outlet.

- () Depress the ON button until it latches. The two pilot lamps should light and the meter should read half way between 12 and 15 in its upper scale (13.8 volts).
- () Depress the ALC button. The meter should read 0.
- () Depress the PWR button. The meter should read 0.
- () Release the ON button. It will require a few seconds for the power supply voltage to bleed down.

POSSIBLE CAUSE CHART

1. Pilot lamps do not light.
 - A. Power supply switch at OFF position.
 - B. Power plug wired incorrectly.
 - C. Power cable from power supply wired incorrectly.
 - D. Defective power switch.
 - E. In mobile installation, polarity of the power supply leads reversed.
 - F. Defective power supply.
 - G. Q1 or Q2 installed incorrectly.
2. Meter does not read 13.8 volts.
 - A. Meter defective.
 - B. Meter switch wiring incorrect.
 - C. Chassis wiring incorrect.
 - D. 180 Ω resistor on meter switches missing.
 - E. Shorting wire across meter terminals not removed.
 - F. Supply voltage to Transceiver incorrect.

POSSIBLE CAUSE CHART

1. Display does not light.
 - A. No voltage at switch S3, section C, pin 6.
 - B. Voltage at "A" on display board too low or missing.
 - C. Refer to the "Display Troubleshooting Chart" (Page 2-54).

- () On the bottom of the chassis, connect the common lead of your voltmeter to the chassis and measure 4.5 volts DC (±.5 volts) at terminal A21 and 10.75 volts DC (±.5 volts) at B1.

POSSIBLE CAUSE CHART

1. 5 or 11 volts incorrect.
 - A. Chassis wiring.
 - B. IC202 or IC203.
 - C. Q1 or Q2.

- () Turn the BAND switch and observe the first digit, which should be blank (not lighted) or read 1 or 2, depending upon the position of the BAND switch:

<u>BAND SWITCH</u>	<u>FIRST DIGIT</u>
3.5	Blank
7.0	Blank
14.0	1
21.0	2
WWV	1
28.0	2
28.5	2
29.0	2
29.5	2

TRANSMIT AUDIO/REGULATOR

- () Plug in circuit board B (#85-1580). Make sure it enters the two side guides properly and is pushed all the way down.
- () Depress the ON button. The pilot lamps should light and the display should read FFFF.F with the BAND switch at 3.5.

POSSIBLE CAUSE CHART

1. The first digit is incorrect.
 - A. IC156.
 - B. BAND switch wired incorrectly.
 - C. BAND switch turned 180°.

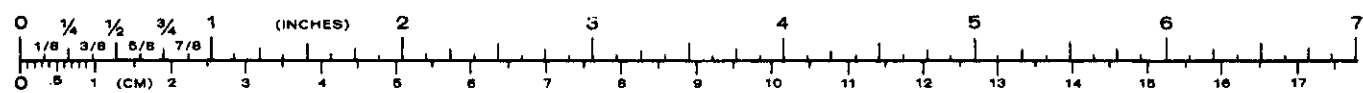

- () Connect your microphone to the MIC socket (see Figure 2-5 on Page 2-18 for microphone cable plug connections).
- () Depress the HI button.
- () Depress the PTT (push-to-talk) switch on your microphone (if your microphone does not have a PTT switch, short terminal 2 of the MIC connector to the chassis). You should hear a click as the relay closes, and another click when you release the switch and the relay opens.

POSSIBLE CAUSE CHART

T/R relay does not pull in.

- A. Relay.
- B. Chassis wiring of the relay circuit.
- C. Q205, Q206, Q207, or Q208.
- D. Accessory plug not installed in rear panel socket.

- () Release the HI button.
- () Depress the PTT switch. The relay should not operate (the PTT switch should operate the relay only when the HI button is depressed).

POSSIBLE CAUSE CHART

- 1. T/R relay operates in LO POWER position.
 - A. Check wiring of LO/HI POWER switch.

- () Depress the VOX and the HI buttons.
- () Speak into the microphone and rotate the VOX GAIN control slowly clockwise until the relay operates.
- () Speak into the microphone and rotate the VOX DELAY control slowly clockwise until the relay holds in for the desired length of time after you cease talking and then drops out (opens).
- () Release the VOX button.

POSSIBLE CAUSE CHART

- 1. VOX does not operate.
 - A. Chassis wiring.
 - B. Q203, Q204.
 - C. IC201.
 - D. D203, D204, D205.
 - E. Microphone not properly wired for VOX operation.

- () Depress the TUNE button. The relay should click as it closes. If it does not click, check the installation of the diodes at BE.
- () Release the TUNE button.
- () Close the relay with the PTT switch. Terminal H1 should measure .7 volts.
- () Release the PTT switch. The voltage should be 0.

POSSIBLE CAUSE CHART

- 1. Voltage at H1 is not .7 volts.
 - A. D1 defective.
 - B. T/R relay wired incorrectly.

- () Release the ON button, and all other buttons.
- () The microphone can be removed, if desired.

COUNTER

- () On card A, use your ohmmeter to check the resistance from the center conductor of J101 to the ground foil. If the meter shows less than infinite (∞) resistance, you must find the cause and correct it before you proceed.
- () Plug in circuit board A (#85-1417).
- () Insert the phono plug (on the shielded lead coming from chassis cutout AA) through the rounded slot in the lateral shield into phono socket J101 on the circuit board.

NOTE: In the following steps, the BAND switch is still at 3.5 and the USB, LSB, and CW buttons are released.

- () Depress the ON button. The display should read 6600.0.

- () Depress the USB button. The display should read 6603.6.
- () Depress the LSB button. The display should read 6606.4.
- () Depress the CW button. The display should read 6604.3.

POSSIBLE CAUSE CHART

1. Incorrect counter readout.
 - A. Time base not running.
 - B. Chassis wiring.
 - C. Diodes D101 through D110.
 - D. IC102, IC104, IC106, IC108, or IC110.
 - E. +5 VDC is low.

- () Release the ON button.

PRELIMINARY VFO OUTPUT ADJUSTMENT

- () Refer to Figure 1-3 (Illustration Booklet, Page 1) and engage the VFO Level Adjust control through hole FY in the side of the VFO assembly. Turn this control to the center of its rotation.

GENERAL INFORMATION FOR ADJUSTMENTS

- () Prepare an 8" blue wire.
- () Refer to Figure 1-5 (Illustration Booklet, Page 2) and connect one end of the 8" blue wire to terminal strip BP lug 1 (S-2).

NOTE: The blue wire just installed will be referred to as the "test lead" in the following adjustment sections. Refer to Figure 1-5 to locate the test points called out in the following steps.

HFO COIL ADJUSTMENT

- () Plug circuit board D (#85-1418) into compartment DD.
- () Plug the receiver front and circuit board (#85-1931) into compartment GG. NOTE: This is one of the preassembled and aligned circuit board.

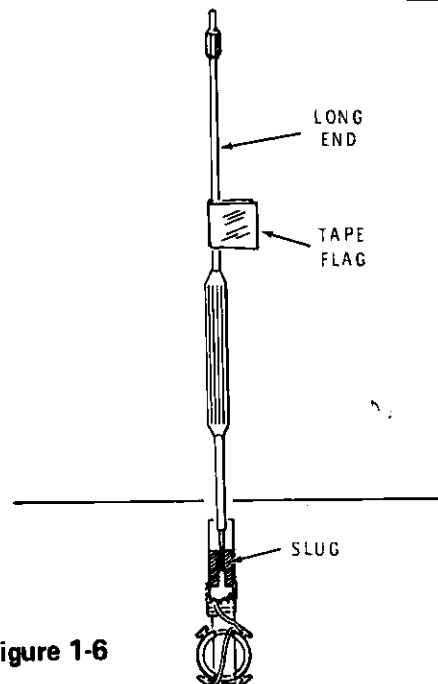

Figure 1-6

NOTE: The high frequency oscillator coils will be adjusted in the following steps. Refer to Figure 1-6 for the method of inserting the alignment tool in the coil, and making a "flag" out of tape for the alignment tool so you can easily see the direction of rotation of the tool.

- () Temporarily solder the free end of the test lead to terminal G6.
- () Depress the USB button. All other buttons should be out (released).
- () Depress the ON button.

Adjust each HFO coil as described in the following chart. Before you adjust each coil for a peak indication on the Transceiver's S meter, turn the slug counterclockwise for an indication of 0 on the meter. Then rotate the slug clockwise for the peak indication. Next rotate the slug in the direction indicated in the chart until the meter indicates S4 (S5 on 3.5 band). NOTE: If the meter indication falls to 0 before you reach S4, adjust the slug until the meter indicates one division higher or lower than S4 (S3 or S5). If you cannot obtain the minimum indication, adjust the slug for a peak indication. Then adjust the slug 1/4 turn in the direction indicated in the chart for that coil.

NOTE: The frequency display may be random during the following adjustments.

BAND SWITCH	COIL NUMBER	ROTATE SLUG FOR PEAK INDICATION. THEN ROTATE SLUG IN DIRECTION INDICATED UNTIL METER INDICATES S4.
() 3.5	L401	turn CW*
() 7.0	L402	turn CCW**
() 14.0	L403	turn CW
() WWV***	L404	turn CW
() 21.0	L405	turn CW
() 28.0	L406	turn CW
() 28.5	L407	turn CW
() 29.0	L408	turn CW
() 29.5	L409	turn CW

*clockwise
 **counterclockwise
 ***Be sure the Bandswitch is at WWV.

- () Rotate the BAND switch through each band to be sure each HFO oscillator is still running. Readjust any band as necessary.

VFO Frequency Adjustment

- () Turn the BAND switch to 3.5.
- () Depress the ON button.
- () Turn the MAIN TUNING knob until the display will go no lower. NOTE: Be sure the VFO jumper cable is installed in the rear panel.
- () Remove the MAIN TUNING knob.

NOTE: If you cannot obtain a reading of 3475.0 in the next step, set the coil slug to the position that gives the reading closest to 3475.0.

- () Insert the coil alignment tool into hole ET in the panel and into the corresponding hole in the VFO enclosure. Fit the tool into the coil slug. Adjust the slug until the display reads approximately 3475.0. You may be able to see this display at two positions of the coil slug. When you have the correct position, the display will read lower with counterclockwise rotation of the alignment tool.

- () Reinstall the MAIN TUNING knob.

VFO Shift Adjustment

- () Turn the MAIN TUNING knob until the frequency displayed is approximately 3800. Then temporarily remove the large knob.
- () Depress the USB button and write down the frequency displayed.

POSSIBLE CAUSE CHART

1. HFO will not oscillate on one or more bands (meter remains at 0).
 - A. BAND switch.
 - B. Chassis wiring.
 - C. Refer to the HFO/premix circuit board in the "Maintenance" section.

- () Release the ON button.
- () Unsolder the test lead from terminal G6 and temporarily solder it to terminal G5.

VFO FREQUENCY, SHIFT, AND LEVEL ADJUSTMENT

NOTES:

1. In the following steps, if the alignment tool will not engage the coil slug, loosen the four VFO mounting screws on the bottom of the chassis and move the VFO forward. After the adjustment is completed, reposition the VFO and tighten the mounting screws.
2. The object of this adjustment is to center the 500 kHz of the 3.5 band within the total VFO tuning range.

- () Insert a small screwdriver into hole ES in the panel, and into the corresponding hole in the VFO enclosure, so the screwdriver engages the notch in the shaft of C1211, the 15-60 pF trimmer on the oscillator board. If the blade on your screwdriver is too large for the panel hole, you may be able to engage the trimmer through the large knob hole.
- () Depress the LSB button.
- () Adjust C1211 carefully until the LSB frequency display is the same as the USB frequency you wrote down, and the same frequency is displayed when either the LSB or USB is depressed. Remove any metal screwdriver before taking the frequency reading.

POSSIBLE CAUSE CHART

1. The same frequency is not displayed in both LSB and USB.
 - A. FUNCTION switch wiring.
 - B. Connector SO1201.
 - C. Diode D1201.

- () To prevent light from shining through, place small pieces of black tape over holes ES and ET (the two VFO adjustment holes) on the back of the panel.
- () Replace the knob and tighten both setscrews.
- () Release the ON button.

Refer to Pictorial 12-38 (Illustration Booklet, Page 2) for the following steps.

- () Turn the BAND switch to 3.5.
- () Loosen the setscrew in the band switch shaft collar.
- () Refer to Detail 12-38A and pull the BAND switch knob and shaft forward until the end of the shaft is over the converter assembly.
- () Refer to Detail 12-38B and position BOTH switch rotors on the ALC/output circuit board (#85-2187-1) so the flat sides of the openings are parallel to the connector edge of the board and so BOTH index notches point away from the connector edge.
- () Plug the ALC/output board into connector K, just back of the converter assembly. Position the switch wafers on the side away from the front panel.
- () Carefully push the BAND switch knob toward the front panel so the end of its shaft enters the two switch rotors on the ALC/output circuit board. Position the circuit board up or down as required.
- () Push the shaft collar snugly against the back of the lateral shield and tighten the setscrew against a flattened side of the shaft.

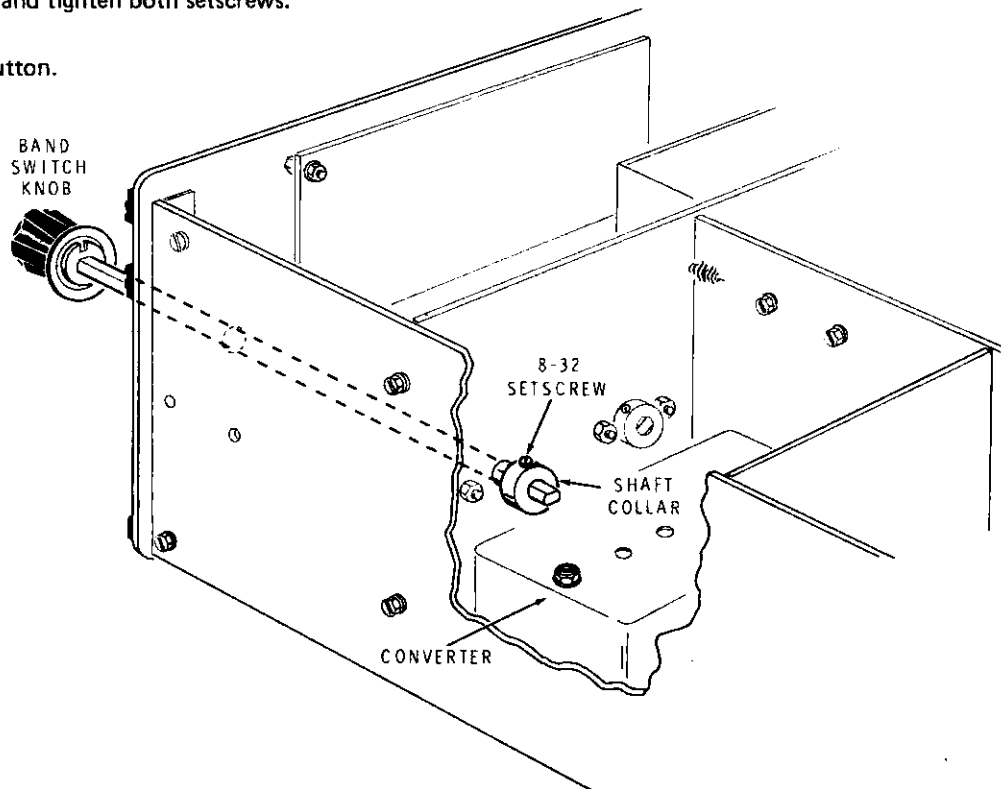

Detail 12-38A

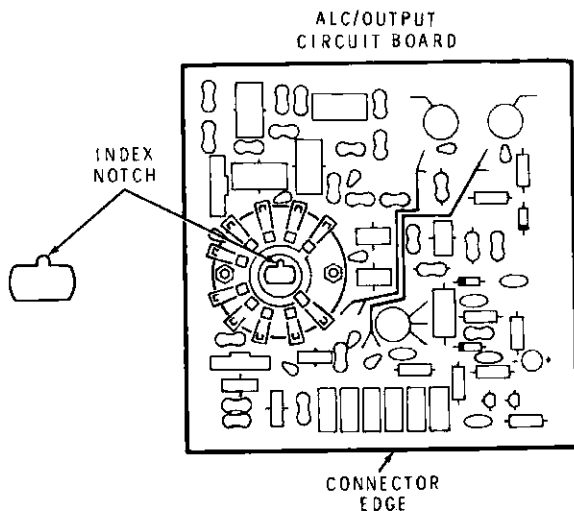
Detail 12-38B

- () Plug the OUT and the IN coaxial cables coming from chassis cutout BL into the OUT and IN phono sockets on the ALC/output circuit board.
- () Plug circuit board E (#85-1581) into its compartment.
- () Plug circuit board F (#85-1462) into its compartment.
- () Connect your station speaker to the SPKR phono socket on the rear panel.
- () Depress the ON button.
- () Turn the RF GAIN knob fully clockwise.
- () Turn the AF GAIN knob clockwise until you hear noise from the speaker.

POSSIBLE CAUSE CHART

1. No sound from speaker.
 - A. Speaker connections.
 - B. AF gain control connections.
 - C. 13.8V missing at pin 19 of board F.
 - D. 11V missing at pin 17 of board F.
 - E. Refer to the "Receiver Troubleshooting Guide."

- () Release the ON button.

VFO Level Adjustment

- () Unsolder the test lead from terminal G5 and solder it to terminal G4.
- () Depress the ON and USB buttons. All other buttons should be released.
- () Turn the BAND switch to 3.5 and tune the Transceiver to 3900.
- () Adjust the VFO LEVEL ADJ control (shown in Figure 1-3) for an indication of S9 on the lower meter scale.
- () Release the ON button.
- () Unsolder the test lead from terminal G4 and solder it to terminal G5.

S-METER ADJUSTMENT

NOTE: The S meter in this Transceiver is not a calibrated meter. It is useful, however, as a relative strength indicator. The following step will direct you to set the S-METER LEVEL ADJUST control to a specific setting. This is only a "rough" setting that will cause the meter to indicate S9 for a received signal that is between 50 and 150 microvolts. You may wish to readjust this control according to personal preference later.

- () Refer to Figure 1-7 (Illustration Booklet, Page 2) and set the S-METER LEVEL ADJUST control to the 7 o'clock position. Use the slot and the plastic stop in the control knob as a reference.

COUNTER CLOCK SETTING

NOTE: The counter clock output will be calibrated against the signal of station WWV, Colorado, on 15,000 kHz or station CHU, Canada, on 7,335 kHz. One of the stations may be more easily received than the other in your location.

- () Connect an antenna (suitable for the frequency of the calibration station selected) to the COM antenna socket. Be sure the rear panel switch is still at COM.
- () Turn the BAND switch to WWV or 7.0, as appropriate.
- () Depress the ON and USB buttons.
- () Tune to zero beat station WWV in the vicinity of 15,000 kHz or station CHU at 7335.0 kHz.



- () Adjust the tuning so the voice announcements sound natural.
- () Adjust the time base trimmer capacitor on the upper right-hand corner of circuit board A (next to the crystal) until the display reads 15,000.0 or 7335.0.
- () Set the BAND switch to 3.5
- () Turn the MIC/CW LEVEL control fully counterclockwise.
- () Turn the SIDE TONE and ANTI-VOX controls fully counterclockwise (rear panel view).

POSSIBLE CAUSE CHART

1. Display cannot be adjusted to agree with WWV or CHU frequencies.
 - A. Y101 not within tolerance.
 - B. C114 defective.

- () Release the ON button.

LOW POWER TRANSMITTER CHECK

- () Refer to Pictorial 12-39 and mount the driver circuit board (#85-1421) on the right side panel. Plug the circuit board into connector J and secure it to the three mounting holes at GG, GH, and GJ with 6-32 × 3/8" screws.
- () Plug the HI and LO shielded leads coming from chassis cutout BL into the corresponding sockets on the driver circuit board.
- () Advance the MIC/CW-LEVEL control and check for power output at the middle of the band and about 25 kHz within the upper and lower band edges. The panel meter should read about 1 on the 0 to 15 (relative power) scale.
- () Release the TUNE button.
- () Turn the BAND switch to the next higher frequency band, depress the TUNE button, and check for output in the middle of the band and at each band edge until all bands 3.5 through 14.0 have been checked.

NOTE: When you install the circuit board in the next step, push down each end of the spring clip mounted to the coil shield until the board is completely seated.

CAUTION: The circuit you will install in the next step has been pretested and aligned. Do not tamper with this circuit board; to do so could decrease performance and will void the warranty.

- () Plug the transmitter IF circuit board (#181-2711) into compartment CC. NOTE: This is one of the preassembled and aligned circuit boards.
- () Connect a 50 Ω nonreactive dummy load (capable of dissipating 100 watts) to the ANT (antenna) socket on the rear panel. NOTE: The dummy load must not have an SWR greater than 1.2:1.
- () Depress the ALC button and repeat the preceding step. The meter should show an ALC indication as the MIC/CW LEVEL control is advanced.
- () Release the ON button.

CAUTION: Never change bands when the TUNE button is depressed.

POSSIBLE CAUSE CHART

1. No meter indication.
 - A. Wiring of the meter switches.
 - B. Refer to the ALC/output filter, driver, or transmitter IF circuit boards in the "Maintenance" section.

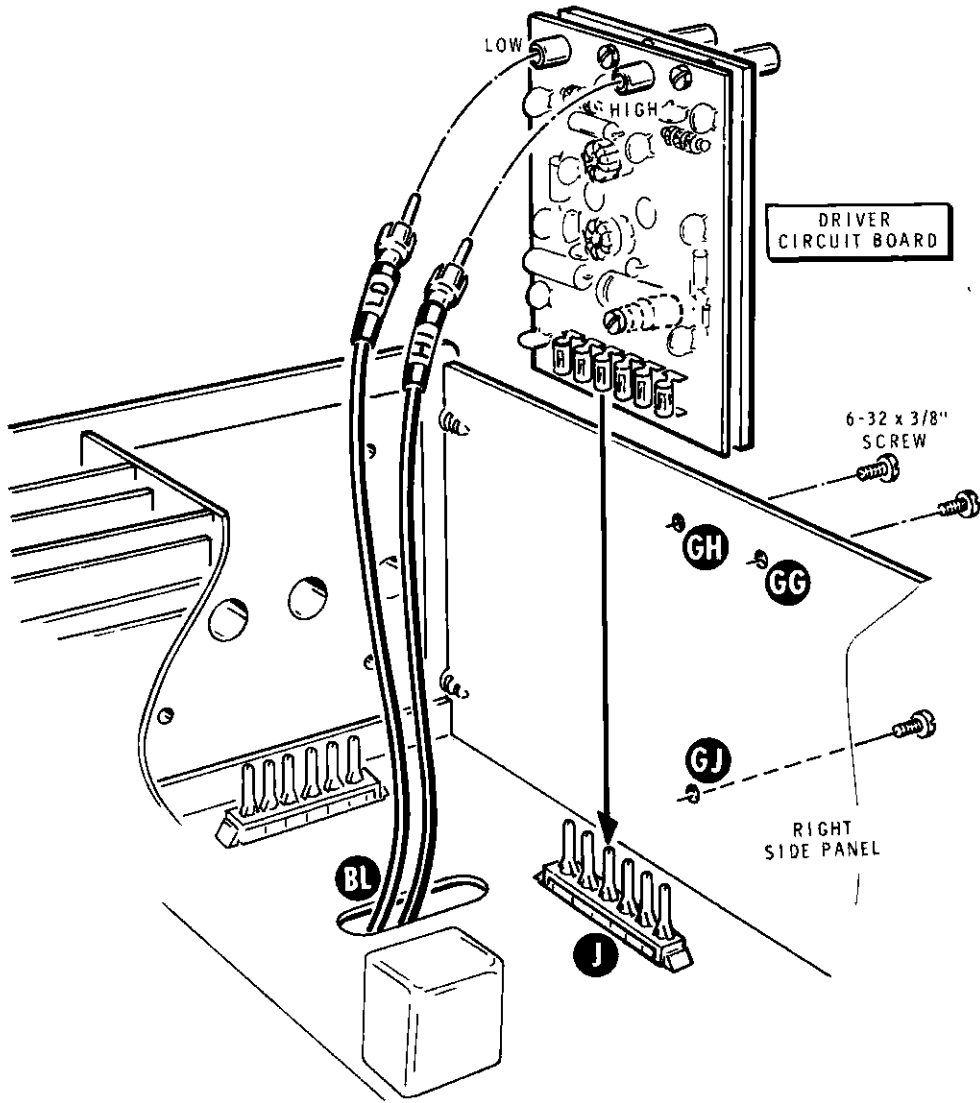

PICTORIAL 12-39

CW CHECK

NOTE: Make sure that a 100 watt dummy load is connected to the ANT jack on the rear panel and that your speaker is connected.

- () Plug a key into the KEY jack on the rear panel. A positive keying voltage is present at this jack, so the leads of any grid block keyer must be reversed.
- () Turn the MIC/CW LEVEL control fully counterclockwise.
- () Turn the SIDE TONE level control fully counterclockwise (rear panel view) if not already done.
- () Depress the PWR, VOX, CW, and ON buttons. All other buttons should be released.
- () Tune to approximately 7000 kHz.
- () Close the key. The meter should read about 1/2 as the MIC/CW LEVEL control is advanced.
- () Close the key and turn the SIDE TONE control clockwise (rear panel view) for a comfortable volume level.
- () Release the ON button.

POSSIBLE CAUSE CHART

1. No CW output or no side tone output.
 - A. Refer to the transmitter audio/regulator circuit board in the "Maintenance" section.

P.A. (Power Amplifier) CIRCUIT BOARD

WARNING: You will be using Dow Corning 340 thermal heat sink compound in the next step and in several other steps in the Manual. Although the compound is not caustic, it may cause temporary discomfort if it gets into your eyes. Should this happen, rinse your eyes with warm water. If the compound gets into your clothing, the clothing may require professional cleaning. The compound contains Zinc Oxides, SiO₂, and slight traces of CO₂.

Refer to Pictorial 12-40 (Illustration Booklet, Page 3) for the following steps.

- () Refer to Detail 12-40A and position the P.A. circuit board (#85-1422) with the aluminium mounting plate up. Then squeeze the contents of two thermal compound pods onto the mounting plate. Use your finger to distribute a thick coating over the plate. Keep the compound off the circuit board.
- () WASH YOUR HANDS.

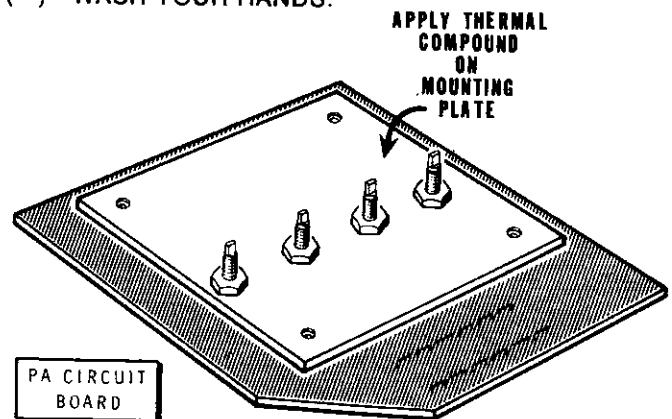

Detail 12-40A

() Grasp the edges of the P.A. circuit board, tilt the top edge toward the front panel, and push the six circuit board connectors down onto connector H so the four power transistor studs fit into the four holes in the heat sink. Then push the P.A. assembly back against the heat sink. Secure the assembly with four 6-32 x 1/2" screws at GR, GS, GT, and GU.

() Push the phono plug on the P.A. cable into the PA OUTPUT socket on the circuit board.

CAUTION: Check to make sure that all five cables in the P.A. compartment are properly connected. If you make an error at this point, you may have to replace the four power transistors.

() Set front panel controls as follows. The position of other controls is immaterial:

MIC/CW LEVEL	Fully counterclockwise
BAND:	7.0
VOX DELAY:	Fully counterclockwise

() Connect the 100 watt dummy load to the ANT socket.

CAUTIONS:

1. **DO NOT EXCEED 30 SECONDS IN HI POWER AND TUNE.**

2. Whenever the Transceiver is operated in both HI power and TUNE, the duty cycle requires an OFF period (receive mode) of five times the TUNE time (for example, 10 seconds TUNE followed by 50 seconds with TUNE button released). This must be carefully observed in the following steps. Complete duty cycle information is shown in the "Operation" section of this Manual on Page 2-21.

() Depress the following buttons; all other buttons should be released: PWR, HI and ON.

() Depress the TUNE button..

() Advance the MIC/CW LEVEL control. The meter should read approximately 14 on the upper scale.

() Depress the ALC button. The meter should read approximately full scale.

() Release the TUNE button.

() Perform the preceding four steps at each position of the BAND switch, being careful to observe the duty cycle. There should be no output at the WWV position.

POSSIBLE CAUSE CHART

1. No output or low output.
 - A. P.A. transistors. Measure voltages as shown under P.A. on Page 2-33.
 - B. Transformers incorrectly wired or shorted. Use an ohmmeter to check for a short circuit from connector pins 5 and 6 to chassis.
 - C. Leads of L813 on ALC Filter board incorrectly wired.
 - D. Gray wire through L813 shorted.
 - E. Chassis wiring (particularly RG-58A/U).
2. No input from driver.
 - A. Check at connector pin 3 with RF probe.

() Release all buttons.

CARRIER SUPPRESSION

() Unsolder the test lead from terminal G5 and temporarily solder it to relay RY lug 9.

() Connect the 50 Ω dummy load to the ANT socket.

() Connect the microphone.

() Depress the USB and ON buttons. All other buttons should be released.

() Turn the BAND switch to 7.0 and tune the Transceiver to 7 200.

NOTES:

1. Key the transmitter (use the microphone PTT switch) for several short periods while making the following adjustments. Prolonged keying of the Transceiver while attempting to achieve an optimum setting creates an undesirable heat rise which could damage the output transistors.

2. Look down into compartment E along the right side of the circuit board and identify control R666 and trimmer capacitor C649. (See Carrier Suppression controls in Figure 1-3, Illustration Booklet, Page 1) It may be necessary to bend the two disc capacitors apart to gain access to the screwdriver slot of C649.

- () Turn the MIC/CW LEVEL fully counterclockwise.
 - () Key the transmitter (with microphone PTT switch) for short periods and alternately adjust R666 and C649 for the best possible null (minimum meter deflection). The meter indication should be at, or near, zero.
 - () Depress the LSB button.
 - () Briefly key the transmitter. The meter indication should be the same as it was in USB.
 - () Depress the USB and HI buttons.
 - () Briefly key the transmitter and again alternately adjust R666 and C649 for the best null.
- NOTE: The meter indication should be S6 or less on the lower meter scale. If it is above S6, remove capacitor C645 (33 pF), install a 62 pF mica capacitor at C645, and repeat the above steps. If the meter indication is still above S6, try removing C645 and repeating the above steps.
- () Release the ON button.
 - () Depress the USB and ON buttons. All other buttons should be released.
 - () Depress the TUNE button.
 - () Turn the MIC/CW LEVEL control clockwise until the meter indicates full scale or a maximum indication.
 - () If there is any meter indication, adjust trimmer C349 on the right side of circuit board C (Figure 1-8) for a null (least indication).
 - () Depress the HI button and again adjust trimmer C349 for the best null.
 - () Depress the LSB button and key the Transceiver. If there is no meter indication, the adjustment is complete. If there is a meter indication, switch back and forth between USB and LSB and adjust C349 for the best possible null at both positions.
 - () Release the ON button.
 - () Reinstall circuit board D.
 - () Unsolder the test lead from relay RY lug 9 and solder it to terminal G5.

3.395 MHz TRAP ADJUSTMENT

- () Remove circuit board D.
- () Preset these controls:

BAND: 3.5
 MIC/CW LEVEL: Fully counterclockwise

This completes the "Test and Adjustments." Proceed to "Final Assembly."

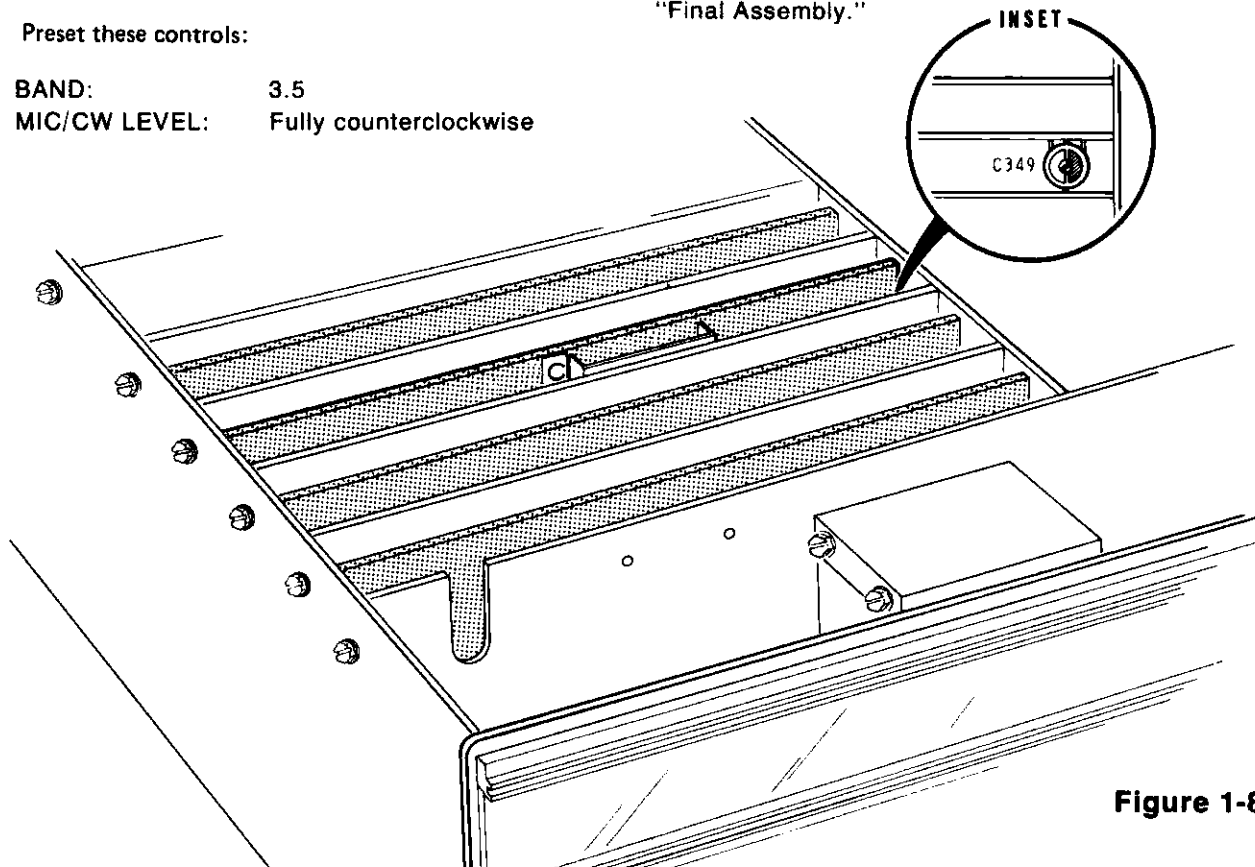
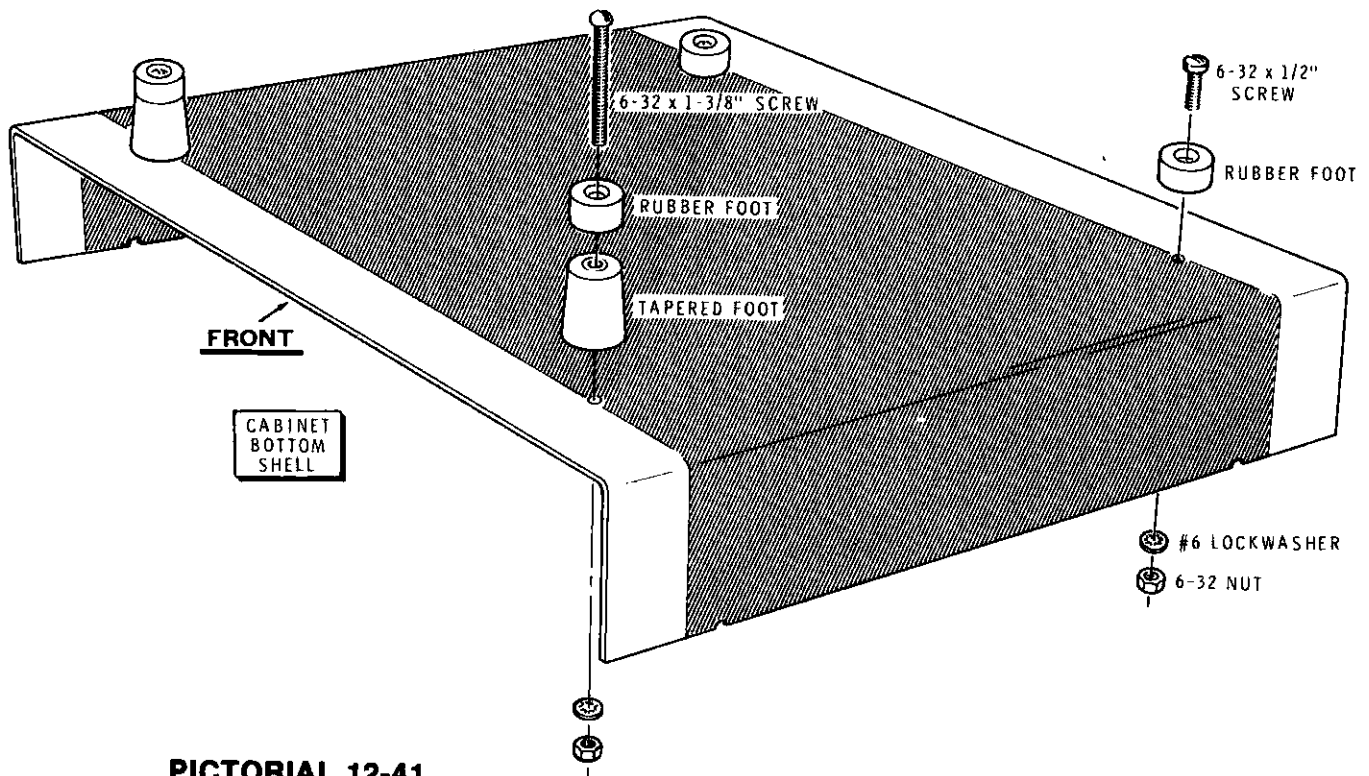

Figure 1-8

FINAL ASSEMBLY



PICTORIAL 12-41

NOTE: The top and bottom cabinet shells are identical except that four holes are provided in the bottom shell for attaching the feet.

Refer to Pictorial 12-41 for the next two steps.

- () If you wish to have the Transceiver cabinet sit level, install a rubber foot at each corner of the bottom cabinet shell. Use 6-32 x 1/2" hardware.
- () If you wish the front panel tilted upward, install a rubber foot on each rear corner with 6-32 x 1/2" hardware. Install a tapered spacer and a rubber foot at each front corner with 6-32 x 1-3/8" hardware.

Refer to Pictorial 12-42 (Illustration Booklet, Page 3) for the next four steps.

- () Attach a cabinet retainer strip to each side panel. Use a 10-32 x 1/2" screw and two #10 flat washers at holes GC and GK on the right side panel and holes GN and GP on the left panel. Leave the screws loose.
- () Place the chassis in the cabinet bottom shell with the cabinet edge between the retainer strip and the #10 flat washers. The bodies of the 10-32 screws must rest in the half-circle cutouts in the cabinet edge.
- () Similarly, place the top cabinet shell on the chassis with its lower edges between the retainer strip and the flat washers. Turn the board pullers down.
- () Tighten the four 10-32 screws.

This completes the assembly of your Transceiver. Proceed to the "Installation" section.

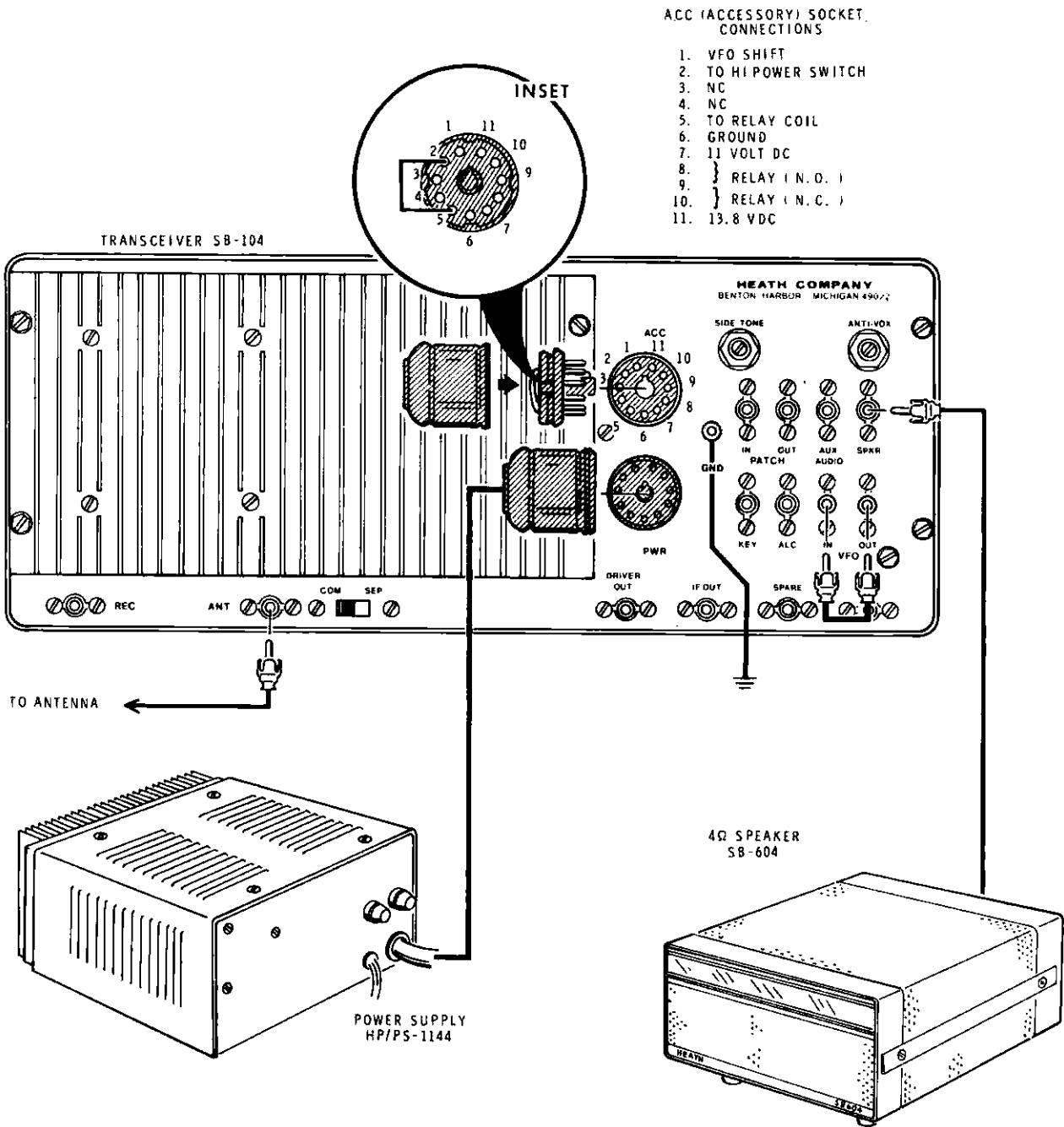

Figure 2-1

INSTALLATION

The Transceiver should be placed where adequate air circulation is present in the area of the heat sink, as there is appreciable heat generated by the final transistors.

FIXED STATION INSTALLATION

Figure 2-1 shows basic fixed station connections. Figure 2-2 (Illustration Booklet, Page 4) shows connections for various accessories that may be used with the Transceiver. Figure 2-3 (Illustration Booklet, Page 5) shows the basic station connected to a linear amplifier. Cables (not furnished) can be prepared following the instructions in Figure 2-4. Make the cables to the lengths required for your installation.

GROUNDING

A good earth or water pipe ground **MUST BE** connected to the ground post on the rear apron of the Transceiver to prevent talk-back and oscillations in transmit. Use the heaviest and shortest connection possible.

Before using a water pipe ground, inspect the connections around your water meter and make sure that no plastic or rubber hose connections are used which interrupt electrical continuity to the water supply line. Install a jumper around any insulating water connectors found. Use heavy copper wire and pipe clamps. It is best to ground all equipment to one point at the operating position and then ground this point as discussed above.

ACCESSORY PLUG

The Transceiver must have a jumper wire connected between pins 2 and 5 on the accessory plug. A cap is furnished for this plug.

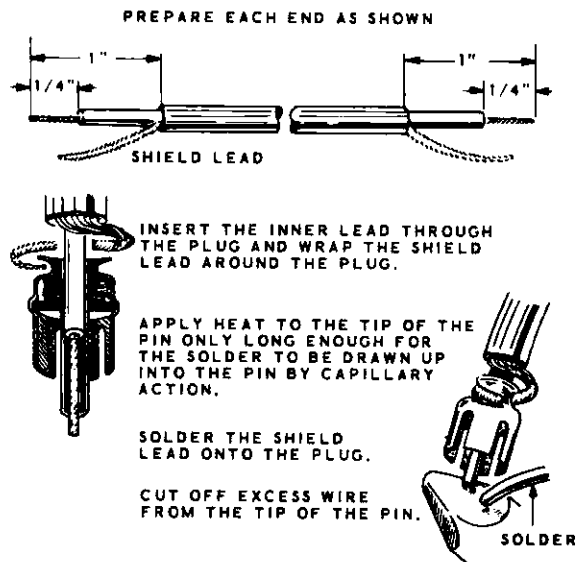

Figure 2-4

VFO IN AND OUT SOCKETS

A shielded jumper wire must be connected between the VFO IN and VFO OUT jacks unless you are using the accessory VFO.

KEY CONNECTIONS

In the CW mode, a positive voltage is present at the KEY socket on the rear panel. If you use a key designed for grid block keying, the usual keyer leads should be reversed so the keyer output lead is connected to the shell of the phono plug and the keyer common, or ground, lead is connected to the pin of the phono plug. If your keyer uses a relay, the lead connections are usually immaterial, although its schematic diagram should be studied to insure proper connections.

LINEAR AMPLIFIER CONSIDERATIONS

Heath Amplifiers

Figure 2-3 shows the installation of the Transceiver with a Heath amplifier.

ALC Connections

If your amplifier has ALC (automatic level control) output provisions, connect a cable between the ALC jack on the Transceiver and the linear amplifier. The ALC bias voltage from the amplifier helps prevent transmitter overloading and "splatter." Although protective circuitry of this nature is a valuable circuit element, it is not a substitute for proper adjustment of the exciter and its drive level to the amplifier.

Antenna Relay Connections

Many amplifiers have an internal transmit-receive relay which is actuated when the relay coil circuit is grounded. Heath amplifiers are of this type. This Transceiver has relay contacts available to operate the transmit-receive relay. The grounding connection may be made by a shielded cable (or other 2-conductor wire) connected to the accessory socket, pins 8 and 9. Use pin 9 for the ground connection and pin 8 for the relay coil.

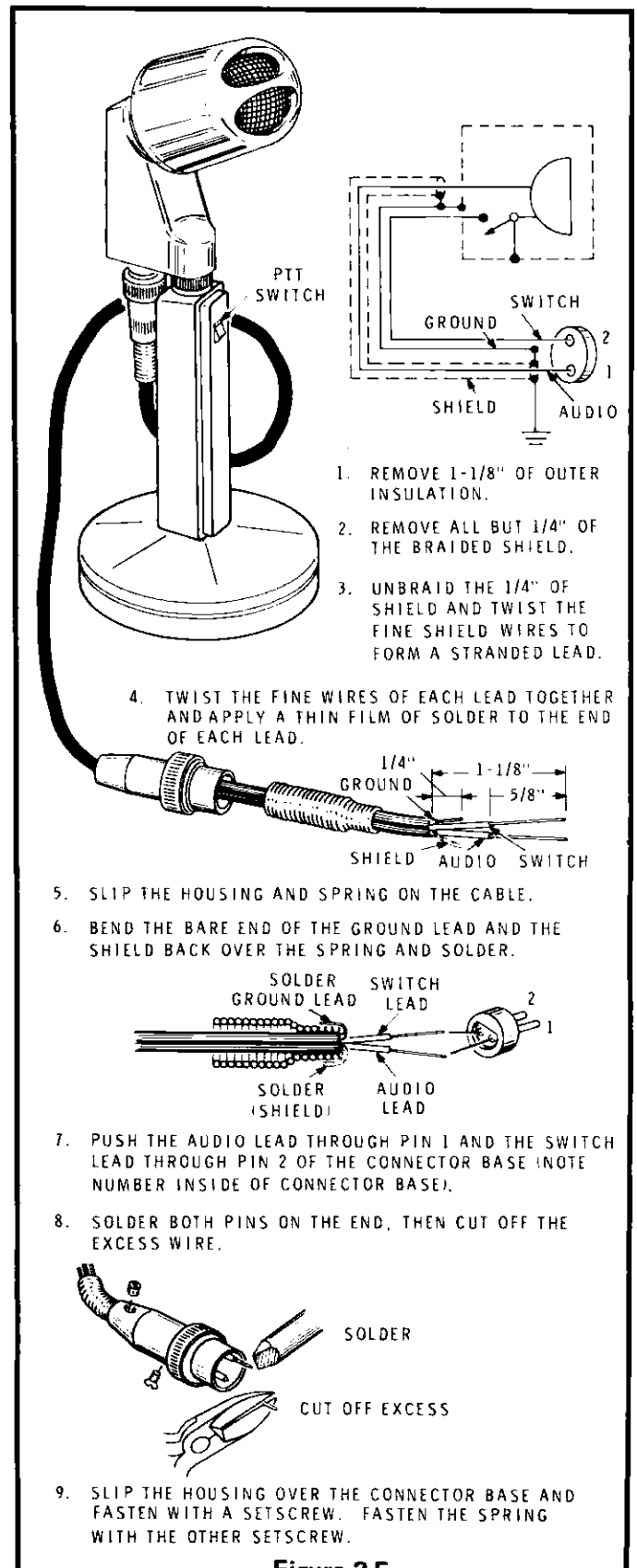

Figure 2-5

MICROPHONE CONNECTIONS

A high-impedance microphone equipped with a push-to-talk switch should be used with the Transceiver so either the PTT or VOX methods may be used to turn on the Transmitter. A two-pin microphone connector (Amphenol 80MC2M) is furnished for this purpose. It should be connected to the microphone cable as directed in the following steps.

Heath Microphones

- () Determine the desired length of your microphone cable, and cut off any excess.
- () Perform the numbered steps in Figure 2-5.

Other Microphones

If you use a microphone different than the one shown, connect the lead from the microphone element to pin 1 of the panel connector. If the microphone has a PTT switch, connect this lead to pin 2. Shield wires, to complete the ground side of the circuit, should be soldered to the spring as shown in Figure 2-5.

Other Power Supplies

Should you use a power supply for fixed station installation other than the one available from the Heath Company, follow the principles shown in Figure 2-6 which shows how the Heath power supply cable is connected. NOTE: The power supply must be capable of supplying between 12.6 and 14.6 volts at 20 amperes.

This completes the "Fixed Station" installation instructions; proceed to the "Operations" section.

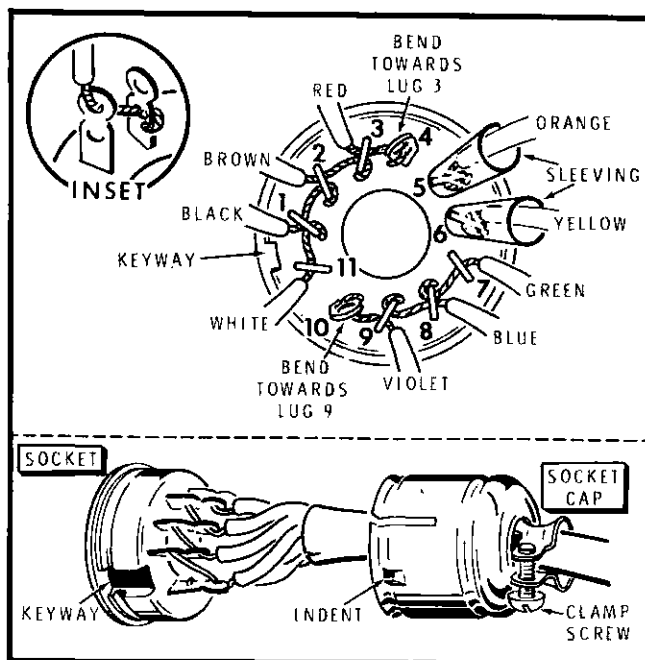

LUGS 11, 1, 2, 3, 4 ----- 13.8 VDC
 LUGS 5, 6 ----- POWER SUPPLY CONTROL
 LUGS 7, 8, 9, 10 ----- NEGATIVE TO CHASSIS

Figure 2-6

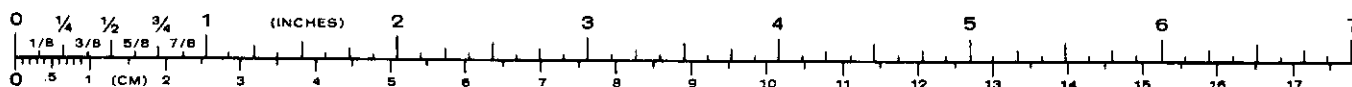



OPERATION

NOTE: YOU MUST HAVE AN AMATEUR RADIO OPERATOR AND A STATION LICENSE BEFORE PLACING THE TRANSMITTER SECTION OF THE TRANSCEIVER ON THE AIR. INFORMATION ABOUT LICENSING AND AMATEUR FREQUENCY ALLOCATIONS IS AVAILABLE FROM PUBLICATIONS OF THE FEDERAL COMMUNICATIONS COMMISSION OR THE AMERICAN RADIO RELAY LEAGUE.

Operation of the Transceiver has been simplified as much as possible to permit rapid adjustment by the operator. Once the initial settings have been made, it should not be necessary to readjust most of the controls. Read the following information carefully. Good operating techniques will provide good clean signals and long trouble-free life of the Transceiver.

IMPORTANT: A transmitter which employs solid-state devices requires different operating techniques than one with vacuum tubes. For example, duty cycle restrictions must be strictly observed because power transistors are not as forgiving as tubes. If the operating parameters of solid-state devices are not exceeded, they will last indefinitely, but they can be easily destroyed by carelessness. As a result, *it is extremely important* that these operating instructions are read, comprehended, and observed. They are not complicated, and will become second nature after you go through them a few times.

A number of the actions listed in this section were covered earlier in this Manual, but are repeated here because they are essential for proper operation of your Transceiver.

CONTROL FUNCTIONS

Refer to Figure 3-1 (Illustration Booklet, Page 6) for a front panel view of the Transceiver and a concise explanation of control functions.

Figure 3-2 (Illustration Booklet, Page 7) shows rear panel controls and connections. Figure 1-3 (Illustration Booklet, Page 1) is a top view of the Transceiver chassis which identifies circuit boards and subassemblies, as well as some additional controls. The following paragraphs describe the control functions more completely.

IDENTIFICATION

The station call letters can be displayed here or the space can be blanked out.

DISPLAY

Displays the frequency to which the Transceiver is tuned, plus or minus 100 Hz. Depress the "100 Hz" button if you want to blank out the right-hand digit, which displays the 100 Hz points. If the accessory VFO is being used for split frequency operation, the display will follow both the receiving and transmitting frequencies.

AF GAIN

Increases the volume of the received signal with clockwise rotation.

RF GAIN

Clockwise rotation increases the receiver sensitivity. This control is usually positioned fully clockwise. Turn the control counterclockwise to reduce sensitivity when exceptionally strong signals are being received, or to reduce adjacent channel interference.

VOX GAIN

Adjusts the input level at which the voice-controlled relay circuits will operate. At this level, either microphone or CW input will silence the receiver circuits and place the transmit circuits in operation.

The VOX button must be depressed to activate the voice-control circuits.

VOX DELAY

Controls the length of time the voice-control circuits will hold the Transceiver in the transmit mode after the input has ceased.

AGC

Selects fast or slow decay time for the automatic gain control, or turns the AGC circuits off.

BAND

Selects the desired amateur band, or station WWV (National Bureau of Standards) at 15 MHz. The frequency printed on the panel is the low frequency end of each range, which extends 500 kHz upward in frequency. The WWV band is for receiving only.

MIC

Connect a high-impedance microphone, preferably with a PTT (push-to-talk) switch. The microphone cable connector is furnished.

PHONES

Connect low impedance headphones through a phones plug. When the plug is inserted in this jack, the loudspeaker is automatically disconnected.

MIC/CW LEVEL

When the USB or LSB buttons are depressed, this control adjusts the audio drive. When the CW or TUNE buttons are depressed, this control adjusts the carrier level.

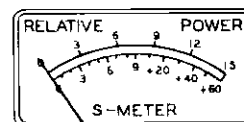

Figure 3-3

METER SWITCH

The meter face is shown in Figure 3-3. The meter gives the following indications with the designated switch button depressed.

- 13.8: Power supply voltage (upper scale).
- ALC:
1. Receiving, meter gives an S-meter indication on the lower scale from 0 to S-9 + 60 dB.
 2. Transmitting, ALC action should not exceed a total change of 6 units on the upper scale. In transmit, it is normal for the meter to read as high as 3 with no input. In SSB, the meter should not read above 3 with no modulation. If it does, replace resistor R322 on circuit board C (6800 Ω) with a 10 k Ω resistor.
- PWR: Indicates relative power output on the upper scale.

VOX

When this button is released, the PTT microphone switch must be pushed to transmit.

When this button is depressed, the voice-control circuits are activated. The position of the USB, LSB, and CW buttons will determine whether the microphone or the key will cause transmission to occur.

400 Hz

When this button is released, the receiver operates in the SSB (2.1 kHz) bandwidth mode.

When this button **and** the CW buttons are depressed, the receiver operates in the narrow (400 Hz) mode (if the Accessory is installed).

NB

If the accessory noise blanker has been installed, it is activated when you depress this button.

USB, LSB, CW

Depress the appropriate button for upper sideband, lower sideband, or CW transmission.

TUNE

Depress this button to secure a carrier for tune-up.

HI

Depress this button for high power output. Release the button for low power output.

ON

Depress this button to turn the Transceiver ON. To turn the Transceiver OFF, push the button again and quickly remove your finger. This will release the button.

ANTI-VOX CONTROL (Rear Panel)

Turn this control clockwise to adjust the VOX circuit so a received signal from the speaker will not feed back into the microphone and cause unwanted transmission.

SIDETONE CONTROL (Rear Panel)

Controls the loudness of the sidetone signal when you are transmitting CW (or in the TUNE mode).

S-METER LEVEL CONTROL

Controls S-meter sensitivity. Instructions for setting this control will be found in the "Test and Adjustment" section under "S-Meter Adjustment" (Page 2-9).

CARRIER SUPPRESSION CONTROLS

These controls on circuit board E balance out the carrier. See "Test and Adjustment" section under "Carrier Suppression" (Page 2-13).

TIME BASE CONTROL

Tune in station WWV until the announcer's voice sounds natural. Adjust the time base trimmer capacitor on circuit board A until the display is 15 000.0.

VFO SHIFT

A trimmer capacitor in the VFO to be adjusted so the display remains constant in either USB or LSB.

VFO FREQUENCY

A coil in the VFO which positions the VFO frequency range to properly cover the amateur bands.

TUNE-UP

NOTE: Once your Transceiver controls have been adjusted for either SSB or CW operation, all that is necessary to place your Transceiver on the air is to depress the ON button. Other than to select your frequency, no other action is required.

INITIAL ACTIONS

Before attempting to use the Transceiver, check to make sure all of the following connections have been completed.

1. An antenna for the band in use should be connected to the rear panel ANT socket. If a power amplifier is used, RG-58A/U coaxial cable should be used to connect the ANT socket to the amplifier input.
2. The ACC plug, with a jumper between pins 2 and 5 (or install the plug of the Accessory VFO), should be installed in the ACC socket on the rear panel.
3. The VFO jumper (or the Accessory VFO) should be installed between the VFO IN and VFO OUT sockets on the rear panel.
4. A 3.2 Ω to 16 Ω speaker should be connected to the SPKR socket on the rear panel, or headphones to the front panel PHONES jack.
5. The power supply cable socket should be connected to the PWR plug on the rear panel.



6. The Transceiver should be connected to a good ground.
7. If a power amplifier is being used,
 - A. The amplifier's ALC output should be connected to the ALC socket on the rear panel.
 - B. Providing the amplifier's transmit-receive relay is the type which is activated by grounding the relay coil, the amplifier's relay coil connection should be connected to pin 8 of the ACC socket. Pin 9 of the ACC socket must be grounded to complete the circuit.
8. If an external receiver is used which has a mute circuit which must be grounded to allow the receiver to operate, this circuit can be connected to pin 10 of the ACC socket. Pin 9 must be grounded. This will ground the mute circuit in the receive mode.

Preset the front panel controls as follows (CW means fully clockwise, CCW means fully counterclockwise):

LEVEL – Mic/CW	CCW
RF GAIN	CW
AF GAIN	CCW
BAND	Any
VOX GAIN	CCW
VOX DELAY	CCW
AGC	Slow
METER	13.8
VOX	Released
400 Hz	Released
NB	Released
MODE	USB or LSB
TUNE	Released
HI	Released
ON	Released
ANTI-VOX (rear panel)	CCW*
SIDETONE (rear panel)	CCW*

*Viewed from the rear.

RECEIVING

The receiver is broad banded and no preselector tuning is required. For best results, the antenna should be designed for a 50 Ω impedance, or an antenna coupler should be used to match the antenna's impedance to 50 Ω .

1. Check the connections in "Initial Actions" (Page 2-23).
2. Connect the transmission line to the ANT socket on the rear panel.
3. The rear panel slide switch should be at COM when you are receiving and transmitting on the same antenna.
4. Depress the ALC and the ON buttons.
5. Depress the USB, LSB, or CW button.
6. Adjust the AF GAIN as desired.
7. If you will use VOX operation, depress the VOX button and place the microphone in the position it will occupy during normal operation, and tune in a strong station. The receiver will usually cycle on and off with the voice peaks of the strong station. Turn the ANTI-VOX control clockwise (as viewed from the rear) until the cycling action ceases. Do not advance the control beyond this point.
8. The AGC switch can be moved to another position, although most SSB operators prefer SLOW. CW operators may prefer FAST or OFF.
9. Depress the NB button to activate the noise blanker, if one is installed.
10. If you use a separate receiving antenna, connect it to the REC socket on the rear panel and set the adjacent slide switch at REC. Transmission will always use the antenna connected to the ANT socket.

TRANSMITTING

TRANSMITTER DUTY CYCLE RESTRICTIONS

The power transistors used in the power amplifier stage of this Transceiver are not as forgiving of overloading and misadjustment as vacuum tubes. The principal source of difficulty is overheating. If you observe the duty cycle parameters carefully, the transistors will last a long time; if you ignore or abuse these parameters, costly replacement will be required. Consequently, it is important that you carefully observe the duty cycle restrictions in the following table when using high power.

NEVER EXCEED 30 SECONDS WITH BOTH THE HI AND TUNE BUTTONS DEPRESSED.

MODE	TRANSMIT TIME	RECEIVE TIME	MAXIMUM CONTINUOUS TRANSMIT TIME
SSB	2 units	1 unit	1 hour
CW	1 unit	1 unit	15 minutes
TUNE	1 unit	5 units	30 seconds

EXAMPLES:

1. In CW, a one minute transmission should be followed by a one minute receive period. In TUNE and HI, a ten-second tune-up requires a 50-second off (receive) period.
2. The on/off times can be averaged over several transmit-receive cycles, but the maximum transmit times must always be observed. For instance, in the CW mode you should only transmit half the time (average) and should never exceed 15 minutes of continuous transmission.

SSB TRANSMISSION

1. Check the connections in "Initial Actions" (Page 2-23).
2. Depress the ALC, USB (or LSB), and ON buttons.
3. For PTT (push-to-talk), use the switch on the microphone to operate the transmit-receive relay.
4. Set the BAND switch.
5. For VOX operations:
 - a. Depress the VOX button.
 - b. Speak into the microphone and advance the VOX GAIN until the relay pulls in reliably when you speak.
 - c. Advance the VOX DELAY clockwise until the relay holds in for the desired length of time after you cease talking.
6. Speak into the microphone and advance the LEVEL control until the panel meter kicks up a total of approximately 6 units (upper scale) on voice peaks. In transmit, it is normal for the meter to read as high as 3 with no input. **CAUTION:** Do not advance the LEVEL control beyond this point because it will not increase the power output, and the final stage may be overdriven, which will result in clipping of voice peaks and sideband "splatter."
7. If high power is desired, depress the HI button.
8. This completes the SSB tune-up procedure and you can proceed to transmit. No warm up time is required.



CW TRANSMISSION

1. Preset the controls as in "Initial Actions" (Page 2-23).
2. Depress the PWR, VOX, CW, and ON buttons.
3. Leave the HI button released for low power operation. Depress the HI button for high power operation.
4. Advance the LEVEL control only to the point where the meter reading ceases to increase. CAUTION: A higher drive level will not increase the power output, but a keying "thump" will develop.
5. Adjust the VOX GAIN control so the relay pulls in instantly when the key is depressed. Adjust the VOX DELAY control for the desired hold-in time.
6. Adjust the SIDETONE control (rear panel) for sound volume with keying (or TUNE).
7. If desired, depress the HI button.
8. This completes the CW tune-up procedure.

AMPLIFIER

If you use this Transceiver with an amplifier, DO NOT advance the Transceiver's gain beyond the point where amplifier output ceases to increase with rotation of the LEVEL control.

OTHER MODES

This Transceiver has been designed for use only in the SSB and CW modes.

TYPICAL OPERATING CHARACTERISTICS

The following conditions are normal and you should not consider them as malfunctions.

1. The relay may activate briefly when you turn the Transceiver on.
2. The relay may activate briefly when you switch modes (LSB, USB, and CW) and the VOX pushbutton is depressed.
3. You may hear a pop from the speaker when you change modes.
4. You may encounter interference from a station operating between 8.395 and 8.895 MHz. You can usually remedy this condition by adjusting coil L715 on the receiver front end circuit board. Adjust this coil for minimum S-meter indication when the interfering station is transmitting.

TROUBLESHOOTING

CONTENTS

Introduction	2-27
Localizing the Trouble	2-28
Chassis Connector Wiring	
Chart	Illustration Booklet, Page 13
VFO/Buffer Troubleshooting Guide	2-28
Receiver Troubleshooting Guide	2-30
Transmitter Troubleshooting Guide	2-32
Display Troubleshooting Guide	2-34
Voltage and Continuity Checks	2-36
Test Chart	2-37
Checking Transistors and Diodes	2-38

INTRODUCTION

The table of "Contents" above shows the different types of information that are available in this section to help you. Begin your troubleshooting by localizing the trouble to a specific area, as described below. Even if you are reasonably sure that you know the area your trouble is in, we suggest that you read through "Localizing the Trouble" because of the additional information that is given there.

Because it is tied in very closely with this part of the Manual, you will often be referred to the "Maintenance" section (see Page 2-39) in the following pages. The "Maintenance" section has complete information on each circuit board, including a "Troubleshooting Chart," an "X-Ray View," A "Voltage Chart," a Schematic, and a "Circuit Description." You may also want to refer to the main Schematic for the entire Transceiver Page 2-113 and to the "Chassis Photographs" (Page 2-95).

ASSISTANCE BY THE HEATH COMPANY

If you are unable to solve a difficulty, refer to the "Customer Service" information inside the rear cover of this Manual. Your Heathkit Warranty is inside the front cover.

If you know that the trouble is on a specific circuit board, you can save expense by sending only that circuit board for repair to either the Heath factory or to one of the Heath Electronic Centers. See Circuit Board Service Police on Page 2-45, which also contains the special Power Amplifier circuit board warranty.

REPLACEMENT PARTS

If you need a replacement part, whether or not it is within warranty period, refer to the "Parts Lists" and to the "Customer Service" information inside the rear cover of this Manual.

LOCALIZING THE TROUBLE

Before you look for any other circuit malfunction, be sure you have the correct supply voltage. Do this by performing the first six steps under "Chassis" on Page 2-3.

Then localize your trouble to a particular area (a single circuit board for example) by using one or more of the following methods:

- Study the functional Block Diagram (Illustration Booklet, Page 8) and the "Theory of Operation" (Page 2-111) carefully. Then use deductive reasoning to pinpoint your trouble to a specific area. (If neither the transmitter or receiver is operating, for example, look for your trouble in one of the circuits that is common to both of them, such as the VFO, the HFO, or a carrier generator.)
- Check the wiring of the under-chassis terminals against the "Chassis Connector Wiring Chart," (Illustration Booklet, Page 13).
- If you know your trouble is in the transmitter, or in the receiver, or in the readout circuits, refer to one of the following sections:

"Receiver Troubleshooting Guide" . . . Page 2-30
 "Transmitter Troubleshooting Guide" . Page 2-32
 "Display Troubleshooting Guide" Page 2-34

- If your Transceiver was in operation for a time and then a difficulty showed up, you can also refer to the "Test Chart" on Page 2-37.

After you localize the trouble to one area:

- Refer to the correct part of the "Maintenance" section (Page 2-39) to troubleshoot any of the circuit boards.
- Very carefully check the front panel, rear panel, and chassis for any wiring errors (Illustration Booklet, Page 13) or poor solder connections.
- Read "Voltage and Continuity Checks" (Page 2-36) before you make any measurements. Also refer to "Checking Transistors and Diodes" (Page 2-38).

When you make repairs on the Transceiver, be sure to eliminate *both the cause and the effect* of the trouble. If, for example, you should find a damaged resistor, be sure you find out what caused the resistor to become damaged (wiring error, etc.). If the cause is not eliminated, the replacement resistor may also be damaged when you turn the Transceiver on again.

VFO/BUFFER TROUBLESHOOTING GUIDE

LSB SHIFT ADJUSTMENT

If the LSB shift adjustment cannot be made, check the DC voltage at the anode (unbanded end) of D1201 on the VFO circuit board. When this diode switch is working properly, the anode voltage will be approximately 0.3 VDC when the LSB pushbutton is depressed, and 0 VDC when the USB or CW button is depressed. Instructions for access to the VFO circuit board are included in the following section.

VFO OUTPUT VOLTAGE

This section is for use when there is no VFO output voltage, or the highest output voltage available is less than 0.3 VDC.

Use an RF voltmeter or an oscilloscope to make RF voltage checks. Be sure to use a high input impedance voltmeter (11 megohms or higher) when you make DC voltage measurements at transistor leads to avoid erroneous readings caused by loading the circuit.

If you get the correct RF voltage reading at the input lead of a component but not at the output lead, the component is probably faulty and should be replaced. If the DC voltages and the resistances measured at each lead (as shown in the table at the end of this section) indicate variations of more than $\pm 20\%$, the resistors in the voltage path may have changed value, the supply voltage may be in error, or a transistor in the circuit could have an internal short circuit.

To check the components on the buffer circuit board, remove the VFO assembly from the chassis and remove the VFO shield so the circuit board is accessible. Reconnect the two 4-wire connectors if they were disconnected during disassembly.

If you are checking the VFO after it has operated satisfactorily in the Transceiver, remove the VFO jumper plug from the VFO OUT socket on the rear panel so the VFO will not be loaded during voltage measurements.

To check the VFO circuit board, remove the mounting nut from L1201, slide the 4-pin connector up out of its slot, and remove the VFO bracket so the entire VFO assembly can be removed from the VFO chassis. Then reconnect the 4-pin connector to its mating connector so the VFO can receive power and the LSB shift voltage.

Make the RF voltage checks in the following steps. In the Test Point column, B = base, C = collector, D = drain, G = gate, and S = source. The DC voltages and resistances to be expected at the transistor leads are given in the table at the end of the steps.

	<u>TEST POINT</u>	<u>RF VOLTS</u>
()	VFO output	0
()	C of Q1205	1.25
()	B of Q1205	0.1
()	C of Q1204	0.35
()	B of Q1204	0.8
()	S of Q1203	0.82
()	G of Q1203	1.7
()	D of Q1202	2.9
()	S of Q1202	1.7

() Repeat the "VFO Level Adjustment" on Page 2-9.

<u>TEST POINT</u>		<u>OHMS RESISTANCE*</u>	<u>DC VOLTS</u>	<u>RF VOLTS</u>
Q1205	Collector	0	0	1.25
	Base	21,000	9.2	.1
	Emitter	1,200	9.8	.3
Q1204	Collector	1,200	9.5	.35
	Base	1,200	1.3	.8
	Emitter	500	.7	.8
Q1203	Gate	3,000	0	1.7
	Source	1,300	2.8	.82
	Drain	1,200	10.8	0
Q1202	Gate	15	0	—
	Source	900	2.	1.7
	Drain	1,000	8.5	2.3

*Negative or common lead to chassis.

() Check for + 11 VDC at the appropriate leads of R1226 on the buffer circuit board, and R1206 on the VFO circuit board.

NOTE: In the following table, if your voltage reading agrees with that in the RF Volts column, follow the instructions in the Action column. If the RF voltage reading varies in excess of 20% from the column figure, disregard the Action column and proceed to the following step.

() Turn control R1232 on the buffer circuit board fully clockwise.

ACTION

Proceed to following step.

Check continuity to Output connection. Check C1234 for a short circuit.

If all Q1205 DC Voltage and resistance readings are correct, replace Q1205.

Check continuity to Q1205.

If all Q1204 DC voltage and resistance readings are correct, replace Q1204.

Check continuity to Q1204.

If all Q1203 DC voltage and resistance readings are correct, replace Q1203.

Check continuity to Q1203.

If all Q1202 DC voltages and resistance readings are correct, replace Q1202.

RECEIVER TROUBLESHOOTING GUIDE

Refer to the "Receiver Block Diagram" (Illustration Booklet, Page 9), which shows how signals flow through the receiver circuits, as you go through the tests on the following pages. Each circuit board is outlined with a dashed line, and the circuit functions are shown as solid blocks inside the outlines.

This troubleshooting guide is divided into the following five tests: "Audio Output," "Product Detector," "Preamplifier," "IF Amplifier and AGC," "Crystal Filter," and "Front End." When you get the correct result for a test, proceed to the next one. If you do not get the correct result, the last step will direct you to the proper part of the "Maintenance" section and will call your attention to some specific areas to check. When you turn to the "Maintenance" section:

1. Refer to any applicable parts of the "Troubleshooting Chart."
2. Refer to the "Voltage Chart" and check the voltages. (Also see "Voltage and Continuity Checks," Page 2-36).
3. Check any questionable diodes and transistors. See Page 2-38.
4. Be sure each circuit is correctly wired and that the correct parts are installed.
5. Read the "Circuit Description" and study the Schematic to better understand and analyze your problem.

TEST CABLE

- () Prepare a 24" shielded test cable as shown in Figures 3-4 and 3-5. NOTE: Install the plug temporarily, as you may need to remove it and reinstall it later.

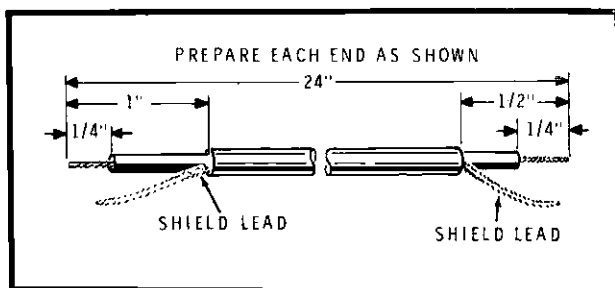

Figure 3-4

AUDIO OUTPUT

- () Turn the power ON.
- () Turn the RF GAIN control fully clockwise.
- () Turn the AF GAIN control to mid-range.

For the following steps, you will need an input signal source to connect to the AUX AUDIO socket on the rear panel. You can obtain this input in either of two ways:

1. Use a 1 kHz signal from an audio generator.
2. Connect a separate speaker to the free end of the 24" test cable. Then, to provide the signal, tap on the cone of the speaker or scratch it with a fingernail.

- () Connect your input signal source to the AUX AUDIO socket on the rear panel. You should hear a sound from your station speaker.
- () If you do not hear any sound from your station speaker, proceed to "Receiver IF/Audio Circuit Board," Page 2-84. Check Q513 through Q518, IC502, and the associated circuitry.
- () Disconnect the input signal source from the AUX AUDIO socket. If necessary, also disconnect the speaker from the test cable.

3.395 MHz TEST SIGNAL

In order to check the remaining stages in the receiver section you will need a 3.395 MHz test signal. You can make this signal available as follows:

- () Locate the 24" test cable.

Refer to Figure 3-6 for the following steps.

- () Cut each lead of an 18 pF disc capacitor to 1/2".
- () Solder one lead of the 18 pF disc capacitor to the center conductor on the free end of the 24" test cable.
- () Lift the end of 100 Ω resistor R645 (on board E), that forms a junction with the ferrite bead. To identify R645, refer to the X-ray view on the fold-out from Page 2-82.

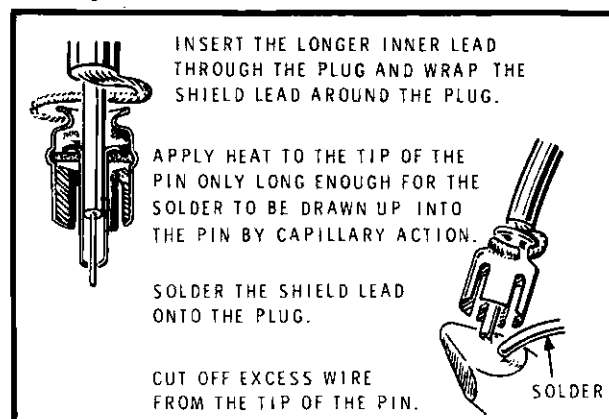

Figure 3-5

- () Connect a 1" jumper wire between the free end of R645 and pin 20 of board E.
- () Unsolder the banded end of diode D603 and pull this lead out of the circuit board.
- () Solder the free lead of the 18 pF capacitor on the test cable to the banded end of diode D603.
- () Replace board E. A 3.395 MHz signal is now available at the phono plug on the test cable.

PRODUCT DETECTOR AND PREAMPLIFIER

- () Insert the phono plug on the test cable into the IF OUTPUT phono socket on the rear panel.
- () Set the MODE switch to the LSB or USB position.
- () You should hear a tone from the speaker.
- () If you do not hear a tone, proceed to "Receiver IF/Audio Circuit Board," Page 2-84. Check T502, D506-D509, IC502 and associated circuitry.
- () Disconnect the phono plug from the IF OUTPUT phono socket.

IF AMPLIFIER AND AGC

- () Turn the AGC off.
- () Hold the phono plug tip of the test signal cable against pin 1 of board F. A tone should be heard from the speaker.
- () If you do not hear a tone, proceed to "Receiver IF/Audio Circuit Board," Page 2-84. Check Q501, IC501, Q502, Q503, and associated circuitry.
- () Turn AGC to FAST.
- () Again hold the test cable phono plug tip against pin 1 of circuit board F. If you do not hear a tone from the speaker, check Q504 through Q511.

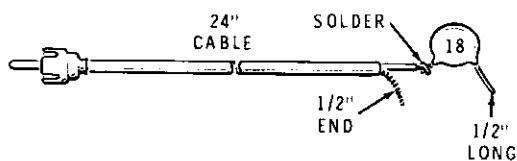

Figure 3-6

CRYSTAL FILTER

- () Inject a 3.395 MHz test signal at pin 1 on board E. A tone should be heard from the speaker.
- () If you do not hear a tone, proceed to "Carrier Gen/X-tal Filter Circuit Board," Page 2-79. Check Q601, Q603, the SSB filter and the associated circuitry.

DISCONNECTING THE TEST CIRCUIT

- () Disconnect the 18 pF capacitor from diode D603.
- () Resolder the free lead of diode D603 to its proper hole in the circuit board.
- () Disconnect the jumper wire that is connected between resistor R645 and pin 20 of board E.
- () Reconnect and solder the free lead of resistor R645 to the circuit board.

FRONT END

- () Remove the phono plug from socket J101 on circuit board A. Then remove the circuit board from your Transceiver.
- () Refer to Figure 3-7 (Illustration Booklet, Page 9) and solder the free lead of the 18 pF capacitor to the foil designated TP on circuit board A. Solder the cable shield wires to the ground foil in the area shown.
- () Carefully plug board A back into its compartment. Look between the foil side of the circuit board and the shield to make sure the "hot" lead of the capacitor does not touch the shield.
- () Replace the phono plug in J101.
- () Insert the phono plug on the end of the 24" test lead into the REC phono socket on the rear panel.
- () Make sure the slide switch on the rear panel is at SEP.
- () You should hear a tone at each 100 kHz point (3.500 MHz, 3.600 MHz, 3.700 MHz etc.) of the VFO dial.
- () If you do not hear a tone, refer to "Receiver Front End Circuit Board," Page 2-89. Check Q701, Q702, and the associated circuitry, the bandpass filter, and the injection of VFO and HFO signals.
- () Disconnect the 18 pF capacitor from the counter board.

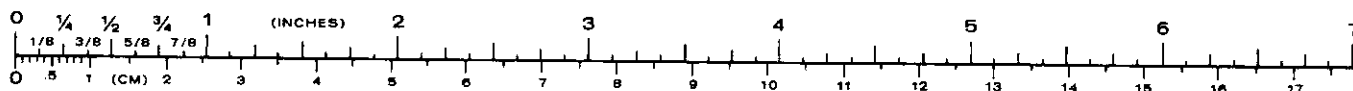

TRANSMITTER TROUBLESHOOTING GUIDE

Refer to the "Transmitter Block Diagram" (Illustration Booklet, Page 10), which shows how signals flow through the transmitter circuits, as you go through the tests on the following pages. Each circuit board is outlined with a dashed line, and the circuit functions are shown as solid blocks inside the outlines.

This troubleshooting guide is divided into the following four sections: "Carrier Generator/Crystal filter," "Transmitter IF," "Driver," and "Power Amplifier." When you get the correct result for a test, proceed to the next one. If you do not get the correct result, the last step will direct you to the proper part of the "Maintenance" section and will call your attention to some specific areas to check. When you turn to the "Maintenance" section:

1. Refer to any applicable parts of the "Troubleshooting Chart."
2. Refer to the "Voltage Chart" and check the voltages in your Transceiver at the points shown. Also see "Voltage and Continuity Checks," Page 2-36.
3. Check any questionable diodes and transistors. See Page 2-38.
4. Be sure each circuit is correctly wired and that the correct parts are installed.
5. Read the "Circuit Description" and study the Schematic diagram to better understand and analyze your problem.

TEST CIRCUIT PREPARATION

When a transmitter circuit board is functioning properly, an RF signal will be present at the output and input. A simple RF detector is furnished which can be used with a high input impedance voltmeter for signal tracing in some low level RF circuits.

CAUTIONS:

DO NOT use the detector on circuits containing more than 30 VAC or 30 VRF.

DO NOT use the detector on the PA circuit board or its output.

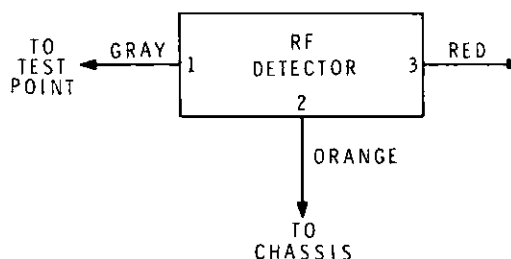

1. TO HIGH INPUT IMPEDANCE VOLTMETER (1 MEGOHM OR HIGHER) DC INPUT.
2. CONNECT VOLTMETER COMMON LEAD TO CHASSIS.

Figure 4-1

To use the RF detector, connect it as shown in Figure 4-1. DO NOT permit the terminal strip lugs to touch anything while the detector is in use. The assembled terminal strip could be wrapped with tape to insulate it.

CARRIER GENERATOR/CRYSTAL FILTER

- () Connect a dummy load capable of dissipating 100 watts to the ANT socket on the rear panel.
- () Set the BAND switch to 3.5.
- () Set the rear panel slide switch to COM.
- () Turn the LEVEL control fully clockwise.
- () Depress the PWR, TUNE, and ON buttons. All other buttons should be released.

Refer to Figure 4-1 and connect the RF detector wires as follows:

- () Red wire to the high input impedance voltmeter.
- () Orange wire to the chassis of the Transceiver.
- () Gray wire to pin 6 of board E.

- () If there is no indication on your voltmeter, proceed to "Carrier Gen/Xtal Filter Circuit Board," Page 2-79. Use the RF detector to check for RF voltages at B of Q602, C of Q604, T601 (the terminal going to connector #22 is grounded), and C of Q611. The indications at the three terminals of T601 will be very low.

NOTE: DC voltage readings should only be made on board E when no RF voltage is present.

- () Disconnect the gray wire from pin 6 or board E.

TRANSMITTER IF

- () Connect the gray wire of the RF detector to pin 24 of board C.
- () If there is no indication on your voltmeter, proceed to "Transmitter IF Circuit Board," Page 2-67. Check for RF voltages on the collectors of Q305, Q304, the emitter of Q301 and pin 4 of IC301 (very low at pin 4).

- () Disconnect the gray wire from pin 24 of board C.

DRIVER

- () Switch your voltmeter to a 10V or 15V range.
- () Connect the gray wire of the RF detector to the anode (unbanded) end of diode D904 on the driver circuit board.
- () If there is no indication on your voltmeter, proceed to "Driver Circuit Board," on Page 2-102. Use the RF detector to check for RF voltage at the cathode (banded) end of diode D904 and at terminal 2 of the connector. Make sure you have +2 VDC on pin 5 of the board.
- () Disconnect the gray wire from diode D904.

P.A.

Use the following check to see if the P.A. transistors are defective. Figure 4-2 shows the P.A. circuit board from the component side. The shaded areas are connected to the secondary center taps of coils L952 and L953.

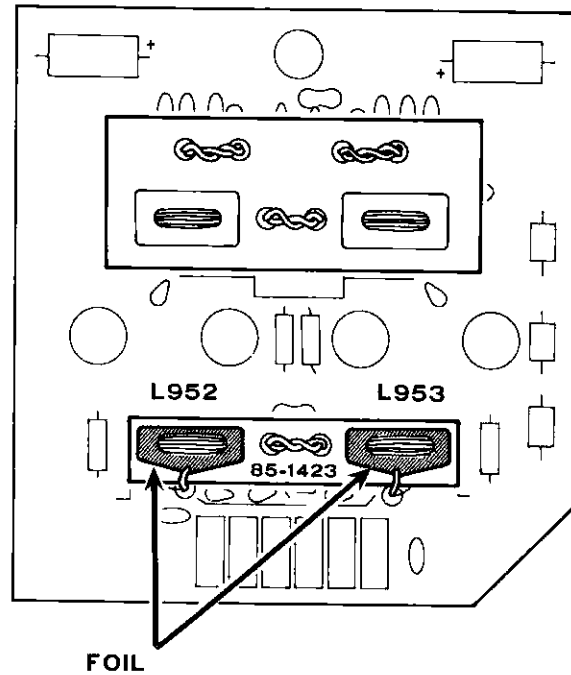

Figure 4-2

- () Push the HI PWR button in.
- () Connect the common lead of your voltmeter to the chassis.
- () Connect the input lead of your voltmeter first to one foil and then to the other. At each foil, you should obtain the following "normal" reading. If you obtain a "bad" reading at either foil, all four final transistors should be replaced (these are only sold by Heath as a matched set of four transistors).

	<u>NORMAL</u>	<u>BAD</u>
TX (HI PWR)	0.65V	1.2 or 0V
RX	0V	1.2V

Refer to "P.A. Circuit Board," Page 2-98, for additional troubleshooting information about this section of the Transceiver.

Refer to "Power Amplifier Warranty" on Page 2-45 for the special one-year warranty on this circuit board.

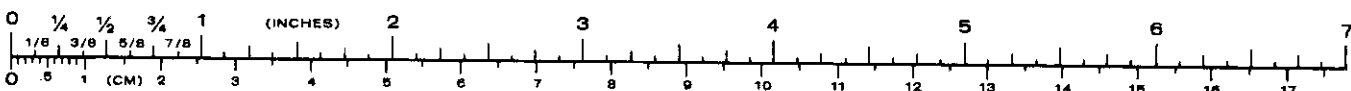

DISPLAY TROUBLESHOOTING GUIDE

As you go through the tests in the following pages, refer to the schematic diagrams of the Counter and Display circuit boards (Illustration Booklet, Page 11), and to the Display Block Diagram (Illustration Booklet, Page 12), which shows how signals flow through the counting and display circuits.

When you get the correct result, proceed to the next test. If you do not get the correct result, turn to "Display Circuit Board" and "Counter Circuit Board" in the "Maintenance" section, which will give you some specific areas to check. When you turn to the "Maintenance" section:

1. Refer to any applicable parts of the "Troubleshooting Chart."
2. Refer to the "Voltage Chart" and check the voltages in your Transceiver at the points shown. Also see "Voltage and Continuity Checks," Page 2-36.
3. Check any questionable diodes and transistors. See Page 2-38.
4. Be sure each circuit is correctly wired and that the correct parts are installed.
5. Read the "Circuit Description" and study the Schematic diagram to better understand and analyze your problem.

Trouble in the counting and display circuits will usually be evidenced by a total or partial blanking of the display, an incorrect display, or an unevenly lighted display.

1. If any segment of a number is brighter than the other segments, it is probably caused by a faulty segment driver or by a short circuit on the circuit board (such as a solder bridge).
 - () Interchange the suspected segment driver IC with one of the others. If both the overbright segment and the interchanged IC move to a new display digit, the IC must be at fault and should be replaced.
 - () If the overbright segment remains at the same location after the driver IC's are interchanged, carefully inspect the circuit board for a solder bridge, leads unintentionally touching each other, and similar conditions.
2. If the entire display is blanked out:
 - () Check for +180 VDC at pin A on the display circuit board. If the voltage is low, disconnect the wire at pin A and check the voltage again. If the voltage at the end of the connecting wire is then satisfactory, but low when connected, look for a short circuit on the display board.
 - () If the +180 VDC is either absent or low, check for +5VDC at the converter input (the terminal under the AGC switch shaft bushing).
 - () If the +5 VDC is not present at the converter input terminal, use voltage or continuity checks to trace the circuit back to Q1, the voltage source, to find the discontinuity.
 - () If the +5 VDC is present, look for the difficulty on the converter circuit board. Check for a faulty transistor or an open diode.
3. If all or part of a digit is not lighted, or the incorrect number is displayed, voltage checks or IC substitution can be used.
 - () If the entire display has only three or four segments lighted, check for +5 VDC at pin B on the display circuit board. If the voltage is not present, use voltage or continuity checks back to Q1, the +5 VDC source.
 - () If there is no premix signal input to be counted, the display will show one of the preset frequencies (6606.4 kHz, 6603.6 kHz, or 6604.3 kHz).
 - () Refer to the schematic diagrams and check the input voltages and the ground connections at each IC in the counter, memory and driver IC's, and at the display tubes. If any of these voltages are incorrect, use a voltmeter to trace the circuit back to Q1, the voltage source. If the supply voltages are satisfactory, check the IC's by one of the following methods.
 - A. To check IC's by substitution, interchange the segment driver IC with another driver IC. If the fault moves with the IC, it should be replaced. If the fault

remains at the same digit, interchange the memory latch and observe the result. If the fault still remains at the same digit, interchange the counter IC.

- B. To use voltage checks on a display string, refer to Figure 4-3 which illustrates the right-hand (sixth) digit of the display.
- () Check voltages at the segment driver output pins. The voltages at pins connected to lighted segments should be lower than at pins connected to unlighted segments.
- () If you know that a 3 should be displayed but segment G (for example) is not lighted, check the voltage at pin 14 of the segment driver. If this voltage is similar in value to the voltages at pins 13, 12, 11 and 10 (all of whose tube segments are lighted), the tube is obviously at fault. If the voltage at pin 14 is higher than the other four pins, then the segment driver may be faulty. However, before making this decision, make the following test.
- () Check voltages at the memory latch output pins. The decimal value of the decoded BCD output voltage should be equivalent to the displayed number. Refer to the memory latch truth table in Figure 4-3 to determine the decimal value from the high and low voltages at the four memory latch outputs. For example, if pins 10 and 15 are high and pins 16 and 9 are low, the value column shows a 3, and the number displayed should be a 3. If so, the segment driver and the display tube are operating satisfactorily.

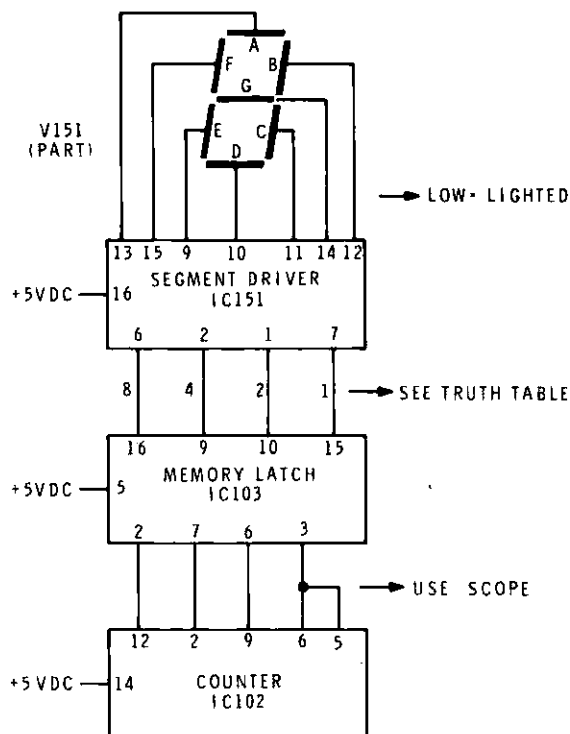

VALUE	MEMORY LATCH PINS			
	16	9	10	15
0	L	L	L	L
1	L	L	L	H
2	L	L	H	L
3	L	L	H	H
4	L	H	L	L
5	L	H	L	H
6	L	H	H	L
7	L	H	H	H
8	H	L	L	L
9	H	L	L	H

L = LESS THAN 0.8VDC
H = MORE THAN 1.5VDC

MEMORY LATCH TRUTH TABLE

NOTE: The counter outputs cannot be checked with a voltmeter as their outputs change rapidly with the count. Use either an oscilloscope or the substitution method described to check the counter outputs.

Figure 4-3

VOLTAGE AND CONTINUITY CHECKS

To measure voltages, use a voltmeter with a high input impedance (11 megohms or higher). A meter with a low input impedance may load down a circuit and cause the readings to be abnormally low.

An ohmmeter is very useful for measuring resistors, determining the continuity of conductors and inductances, and making a rough check of the serviceability of diodes and transistors (as in "Checking Transistors and Diodes," Page 2-38).

First, before you check a component on any circuit board, check for the presence of the proper DC input voltage and check the ground connections from the circuit board connectors to the chassis. These are shown on the individual schematics for the circuit boards in the "Maintenance" section Page 2-39 and on the large fold-in Schematic.

Check all nongrounded circuit board connectors to make sure there is not a short circuit (zero resistance) to the chassis or to adjacent pins. Do this because one fine strand from a conductor can sometimes protrude and touch an unintended location, thus causing a short circuit. These are usually difficult to see.

When you are told to check a component, refer to the part of the "Maintenance" section which deals with the circuit board upon which the part is located; then measure the

voltages around the component and check them against those shown in the "Voltage Chart." It will usually be necessary to use the extender board to gain access to the points to be measured. Any voltage deviation of more than 20% should be considered as possibly indicating some sort of malfunction.

There can be various causes of a voltage variation. For instance: the supply voltage may have changed, there may be a malfunction in the Transceiver's power supply, some resistor between the test point and the voltage source in the Transceiver may have changed value, or a bypass capacitor may have short circuited. Use your voltmeter and trace the voltage path back until you get a normal voltage reading. When this point is reached, the probable causes of trouble can be limited to a very few components, which can then be thoroughly investigated.

CAUTION: When you check transistors, be very careful that you do not touch two leads at the same time with the meter probe. This can destroy a transistor instantly.

The complete absence of a designated voltage indicates a poorly soldered connection, a break in the foil, a power supply failure, or a similar problem.

In such cases, turn the Transceiver OFF and use your ohmmeter (on its RX1 scale) to check the continuity of the path to the voltage source. Use the "X-Ray View" (see "Maintenance," Page 2-39) and the schematic diagram to determine where the path is.

TEST CHART

This chart uses selected parts of the "Test and Adjustment" section to check circuit boards. It will be most useful for the type of difficulty that shows up after the Transceiver has been in operation for some time. Refer first to the "Function" column and locate the function that is not operating properly on your Transceiver. Then perform the proper tests (and adjustments in some cases) as described in the next column.

Be sure to see "After you localize the trouble to one area:" on Page 2-28.

BOARD	FUNCTION	DO TEST UNDER (see index Page 2-43)	PAGE
B	Transmitter audio amps., Vox ampl., keying, relay driver, regulator	"Transmit Audio Regulator"	2-4
A	Frequency display, memories, counters	"Counter"	2-5
D	HF oscillators, Trans- mitter bandpass filters, VFO shift	"HFO Coil Adjustment" "VFO Shift Adjustment"	2-6 2-7
K	ALC, filter	"Receiver Front End Alignment"	2-89
E	LSB, USB, and CW genera- tors, balanced modulator, SSB and CW filters		
F	Receiver IF, AF, AGC		
G	Receiver front end, band- pass filters.		
C	Transmitter IF amps., ALC, bandpass filters	"Low Power Transmitter Check"	2-10
J	Driver		
H	Power Amplifier	"P.A. Circuit Board"	2-12

CHECKING TRANSISTORS AND DIODES

SILICON BIPOLAR TRANSISTOR CHECKING

To check a transistor accurately, you should use a transistor checker. However, if one is not available, you can use an ohmmeter to determine the general condition of any of the bipolar transistors in this kit. The ohmmeter used must have at least 1 volt DC at the probe tip to exceed the threshold of the diode junctions in the transistor being tested.

To check a transistor with an ohmmeter, proceed as follows. NOTE: Identify the transistor leads on Page 2-44.

1. Unsolder and remove the transistor from the circuit.
2. Set the ohmmeter to the RX1000 range.
3. Connect one of the ohmmeter test leads to the base (B) of the transistor. Touch the other meter lead to the emitter (E) and then to the collector (C). Both readings should be the same, but may be either high or low. If one reading is high and the other low, the transistor should be replaced.
4. Repeat step 3 with the test leads reversed.

NOTE: In the unusual case when the readings are all low or all high, no matter which ohmmeter lead is connected to the base, the transistor should be replaced.

MOSFET AND JFET CHECKING

Insulated gate type MOSFET's are used at Q501 on the receiver/IF audio circuit board, and at Q701 and Q704 on the receiver front end circuit board. JFET's are used at Q1202 and Q1203 on the VFO/buffer circuit boards. Usually, any defect in these devices is found to be an internal short circuit between the source and the gate of the JFET (between the source and one of the gates of the MOSFET). These devices can be checked for serviceability by one of the two following methods.

Method 1

1. Remove the device from the circuit.
2. Set your ohmmeter to the R X 10 K range.
3. Connect the common meter lead to the gate and the hot lead to the source.
4. If the device is good, a reading near infinity will be obtained. If you do not get this reading, reverse the meter leads.
5. If you do not get a reading near infinity with the meter leads connected either way, the device should be replaced.

Method 2

1. Remove the device from the circuit.
2. Set your ohmmeter to the R X 10 K range.
3. Connect the gate to the source.
4. Connect the common meter lead to the gate and source and connect the hot lead to the drain.
5. The meter reading should be in the lower part of the meter scale.
6. If the reading is not in the lower part of the meter scale, the device should be replaced.

DIODE CHECKING

To check a diode, unsolder one end from the circuit board, pull the lead up out of the circuit board hole, and proceed as follows:

1. Set the ohmmeter on the R X 1000 range.
2. Connect one of the ohmmeter test leads to the cathode (banded) end of the diode. Connect the other test lead to the other end of the diode. Note the reading. Then reverse the meter leads and take another reading. One reading should be high and the other low (at least 10:1). If both the readings are either low or high, the diode should be replaced.

MAINTENANCE

INDEX

Pin-out Diagrams	2-40
Identification Charts	2-43
Circuit Board Service Policy	2-45
VFO and Buffer Circuit Boards	2-47
VFO/Filter Circuit Board	2-50
Converter Circuit Board	2-52
Display Circuit Board	2-54
Counter Circuit Board (A)	2-57
Transmitter Audio/Reg Circuit Board (B)	2-62
Transmitter IF Circuit Board (C)	2-67
HFO/Premixer Circuit Board (D)	2-74
Carrier Gen/Xtal Filter Circuit Board (E)	2-79
Receiver IF/Audio Circuit Board (F)	2-84
Receiver Front End Circuit Board (G)	2-89
P.A. Circuit Board (H)	2-98
Driver Circuit Board (J)	2-102
ALC/Output Circuit Board (K)	2-104

This part of the Manual presents, for each circuit board, a section which contains the Schematic diagram, an "X-Ray View," a "Voltage Chart," a "Troubleshooting Chart," and a "Circuit Description." The "X-Ray View" permits you to simulate viewing both sides of the circuit board simultaneously so you can easily trace the foil pattern between components.

The pin-out diagrams and Identification Charts provide a summarized reference to all the solid-state devices used in the Transceiver.

To find the Part Number of a component for the purpose of ordering a replacement part:

- A. Find the circuit component number (R5, Q2, etc.) on the proper "X-Ray View" or the Schematic.
- B. Locate this same number in the "Circuit Component Number" column of the proper "Parts List."
- C. Adjacent to the circuit component number, you will find the Part Number and Description, which must be supplied when you order a replacement part.

Pin-out Diagrams

Display Tubes and Integrated Circuits

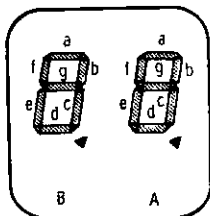

VIEWED FROM FRONT

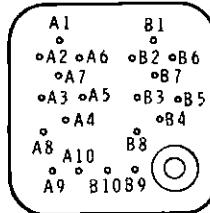

VIEWED FROM BACK

SEGMENT	PIN NUMBER
a	1
b	2
c	3
d	4
e	5
f	6
g	7
DECIMAL ANODE	8 (NOT USED) 9
	10 (NOT USED)

V151, V152, V153,
PART NO. 411-295,
SP-352

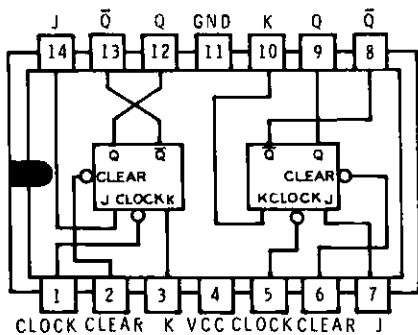

CLOCK CLEAR K VCC CLOCK CLEAR J

NOTE: t_n - BIT TIME BEFORE CLOCK PULSE
 t_{n+1} - BIT TIME AFTER CLOCK PULSE

IC117, IC118
PART NO. 443-5
SN7473N

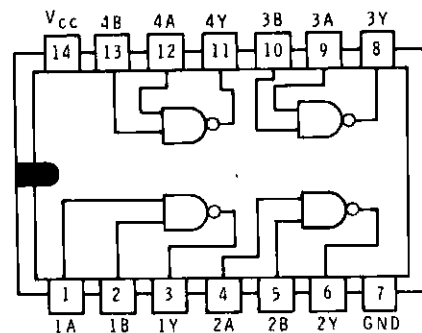

IC112
PART NO. 443-1
SN7400N

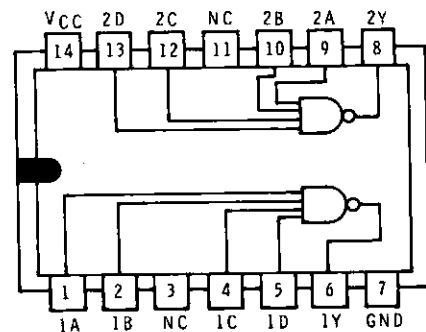

IC119
PART NO. 443-2
SN7420N

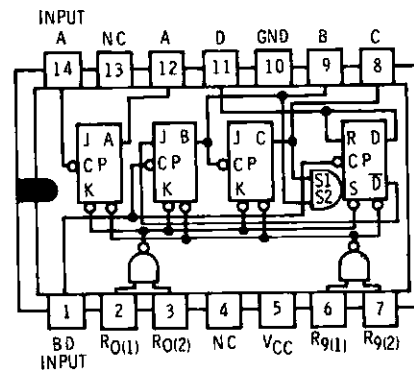

IC113, IC114, IC115, IC116
PART NO. 443-7
SN7490N

TRUTH TABLE
BCD COUNT SEQUENCE

COUNT	OUTPUT			
	D	C	B	A
0	0	0	0	0
1	0	0	0	1
2	0	0	1	0
3	0	0	1	1
4	0	1	0	0
5	0	1	0	1
6	0	1	1	0
7	0	1	1	1
8	1	0	0	0
9	1	0	0	1

TRUTH TABLE
(Each Flip-Flop)

t_n		t_{n+1}
J	K	Q
0	0	Q_n
0	1	0
1	0	1
1	1	\bar{Q}_n

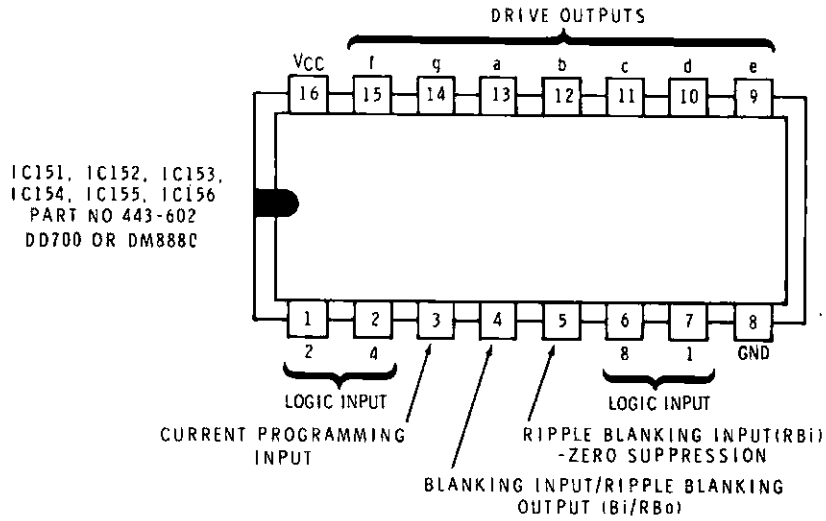

TRUTH TABLE														
DECIMAL OR FUNCTION	BCD INPUT						SEGMENT DRIVE OUTPUT							DISPLAY
	RBI	8	4	2	1	Bi/RBo	a	b	c	d	e	f	g	
0	1	0	0	0	0	1	0	0	0	0	0	0	1	0
1	X	0	0	0	1	1	1	0	0	1	1	1	1	1
2	X	0	0	1	0	1	0	0	1	0	0	1	0	0
3	X	0	0	1	1	1	0	0	0	0	1	1	0	0
4	X	0	1	0	0	1	1	0	0	1	1	0	0	0
5	X	0	1	0	1	1	0	1	0	0	1	0	0	0
6	X	0	1	1	0	1	0	1	0	0	0	0	0	0
7	X	0	1	1	1	1	0	0	0	1	1	1	1	1
8	X	1	0	0	0	1	0	0	0	0	0	0	0	0
9	X	1	0	0	1	1	0	0	0	0	1	0	0	0
10	X	1	0	1	0	1	0	0	0	1	0	0	0	0
11	X	1	0	1	1	1	1	1	0	0	0	0	0	0
12	X	1	1	0	0	1	0	1	1	0	0	0	1	0
13	X	1	1	0	1	1	1	0	0	0	0	1	0	0
14	X	1	1	1	0	1	0	1	1	0	0	0	0	0
15	X	1	1	1	1	1	0	1	1	1	0	0	0	0
BI	X	X	X	X	X	0	1	1	1	1	1	1	1	1
RBI	0	0	0	0	0	0	1	1	1	1	1	1	1	1

NOTE: LOGIC "1" ON ALL INPUTS AND RBo IS DEFINED AS THE HIGH TTL/DTL STATE. LOGIC "0" ON OUTPUTS a-g IS DEFINED AS THE LOW OR CURRENT SINKING STATE (DISPLAY ON STATE). X IS DEFINED AS "DON'T CARE" CONDITION

Identification Charts

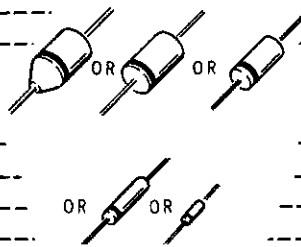
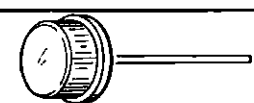
HEATH PART NO.	TYPE	VIEW	TOTAL	USED IN PARTS LIST NO.										TX IF	FRONT END
				1	2	3	4	5	6	7	8	9	10		
DIODES															
56-6	1N710 .6.8V		1										1		
56-16	1N751 .5.1V	<p>NOTE: HEATH PART NUMBERS ARE STAMPED ON MOST DIODES.</p> 	2		2										
56-19	VR-9.1		2		1								1		
56-20	1N295		3						3						
56-24	1N458		43	1		12				8				10	12
56-26	1N191		7			1		2		1			3		
56-56	1N4149		69	3	5	24	10				9		3	9	6
56-59	1N750A .4.7V		2								1			1	
56-87	FH1100		24			4				4	4			4	8
56-89	GD510		2							1			1		
56-97	VR-7.5		1	1											
57-27	1N2071	4				4									
57-64	DRS-110	12						2						10	
57-65	1N4002	7		2				2						3	
57-34	1N3491		1										1		

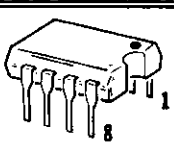
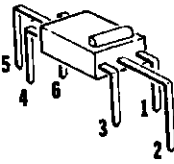
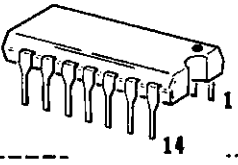
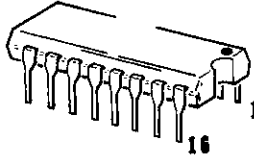
HEATH PART NO.	TYPE	VIEW	TOTAL	USED IN PARTS LIST NO.										TX IF	FRONT END
				1	2	3	4	5	6	7	8	9	10		
INTEGRATED CIRCUITS															
442-18	MC1350P		2										1		1
442-48	MFC6030		2		2										
442-71	LM3900		2		1								1		
443-1	SN7400N		1				1								
443-2	SN7420N		1				1								
443-5	SN7473N		2				2								
443-7	SN7490N		4				4								
443-70	SN74H103CU		1				1								
443-628	74196		5				5								
443-13	2N7475N		5				5								
443-602	DD700 OR DM8880		6				6								

HEATH PART NO.	TYPE	VIEW	TOTAL	USED IN PARTS LIST NO.										TX IF	FRONT END	
				1	2	3	4	5	6	7	8	9	10			
TRANSISTORS																
417-893	2N5109		1													1
417-154	2N2369		4		2	1										1
417-205	2N3866		3		1											2
417-118	2N3393		1	1												
417-201	X29A829		7		4						3					
417-162	MHT9210		2												2	
417-169	MPF105		2	2												
417-134	MPS6520		1		1											
417-172	MPS6521		4			4										
417-244	2N5089		2													2
417-293	2N5770		1				1									
417-801	MPSA20		25		5				2	9	9					
417-224	MPSU05		2			2										
417-233	2N3643		1							1						
417-234	2N3638A		3	1							1					1
417-235	2N4121		3								3					
417-274	40673		1								1					
417-263	SJE607		1								1					
417-264	SJE608		1									1				
417-830	CD-3342 OR PT6619		2					2								
417-831-1	PT5767 * (SET OF 4 417-831)		1											1		

*HAS WIDE LEADS

Circuit Board Service Policy

SERVICE FACILITIES — Service facilities are available at our factory and at Heathkit Electronic Centers to service the circuit boards used in the Model SB-104A Transceiver.

IN WARRANTY — When any of the circuit boards listed below are returned to any Heath service facility within 90 days of the date of your invoice, defective parts will be replaced without charge for parts or labor. A circuit board that requires service due to causes other than defective parts will be repaired at a fixed charge.

OUT OF WARRANTY — After your 90-day kit warranty expires, any of the circuit boards listed below will be repaired by a Heath service facility at the fixed charge plus the cost of parts replaced.

CIRCUIT BOARDS — The Circuit Board Service Policy applies to the following circuit boards:

CIRCUIT BOARD

	VFO/Buffer (entire assembly)
A	Counter
B	Transmitter Audio/Regulator
C	Transmitter IF
D	HFO/Premix
E	Carrier Generator/Crystal Filter
F	Receiver IF/Audio
G	Receiver Front End
H	Power Amplifier
J	Driver
K	ALC/Output Display Converter

POWER AMPLIFIER WARRANTY — Within 90 days from the date of your invoice, the power amplifier circuit board, completed according to the instructions in the Assembly Manual, may be returned to the factory or to a Heathkit Electronic Service Center for repair or replacement, at our option. The power amplifier circuit board must be returned for warranty replacement of the output transistors.

After 90 days, a matched set of four transistors used on the power amplifier circuit board may be purchased from the Heath Company. Because of the necessity for balancing the transistor characteristics, they are available only as a set of four. Use part number 417-831-1 to order the set of four.

HOW TO RETURN CIRCUIT BOARDS BY MAIL

A special circuit board packing carton (#380-846) has been included in Parts Pack #11 of your Transceiver. This is the collapsed carton which is packed flat and has red rectangles on the sides so it will be easily recognized among other pieces of incoming mail and receive priority handling. Save both the carton and some loose packing material for future use, should it be necessary. Include the following information in the package:

1. Your name, address and, zip code.
2. A letter describing the symptoms observed in your Transceiver, and copies of any prior correspondence.
3. The chassis series number (find this on the blue and white label).
4. Date of purchase and invoice number.
5. Authorization for us to return your circuit board COD for the service, parts, and shipping charges.

Ship the carton by insured parcel post to "Heath Company, Benton Harbor, Michigan, 49022."

IMPORTANT — The policy stated above applies only to the circuit boards named. If the problem appears to be elsewhere and cannot be resolved with the Manual troubleshooting suggestions, check with our Technical Consultants Section at the factory or at your nearest Heathkit Electronic Center before returning the kit or any components for service.

Schematic Notes

NOTES:

1. ALL RESISTORS ARE 1/2 WATT UNLESS OTHERWISE SPECIFIED. VALUES ARE IN Ω (OHMS). K=1,000; M=1,000,000.
2. CAPACITOR VALUES LESS THAN 1 ARE IN μ F. VALUES OF 1 AND HIGHER ARE IN pF UNLESS OTHERWISE SPECIFIED.
3. THE BANDSWITCH IS SHOWN AT THE 3.5 MHz POSITION AND THE MODE SWITCH AT LSB.
4. REFER TO THE PIN-OUT DIAGRAMS AND IDENTIFICATION CHARTS FOR INFORMATION CONCERNING TRANSISTORS, DIODES, AND INTEGRATED CIRCUITS (ICs).
5. REFER TO THE APPROPRIATE PARTS LIST FOR CROSS-REFERENCE BETWEEN SCHEMATIC COMPONENT DESIGNATIONS AND PART NUMBERS.
6. CHASSIS WIRING - SEE THE LARGE FOLD-IN SCHEMATIC.
7. SYMBOLS:

 = A PLUG-IN CONNECTION.

 = CIRCUIT BOARD GROUND.

 = CHASSIS GROUND.

 = IDENTIFIED CIRCUIT BOARD HOLES.

 = CIRCUIT BOARD EDGE CONNECTOR.

 = FERRITE BEAD.

 = PHONO SOCKET.

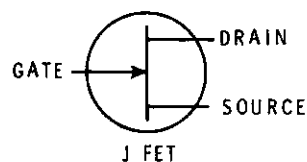
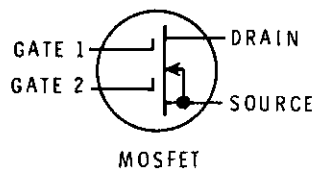
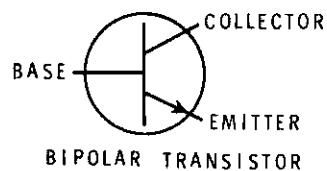

VFO and Buffer Circuit Boards

TROUBLESHOOTING CHART

SYMPTOM	POSSIBLE CAUSE
Frequency drift or warble.	<ol style="list-style-type: none">1. Check all mechanical connections.2. Check cemented capacitors on oscillator circuit board.3. Shorten wires to coil L1201 and resolder them securely.4. Resolder bare wires from tuning capacitor C1201 to circuit board solder lugs.
Less than .2 to .3 VAC VFO output.	<ol style="list-style-type: none">1. Refer to "VFO/Buffer Troubleshooting Guide."

NOTE: Heath part numbers that correspond to the circuit component numbers will be found in the Parts List starting on Page 1-11 of the Assembly Manual.

VFO and BUFFER SCHEMATIC

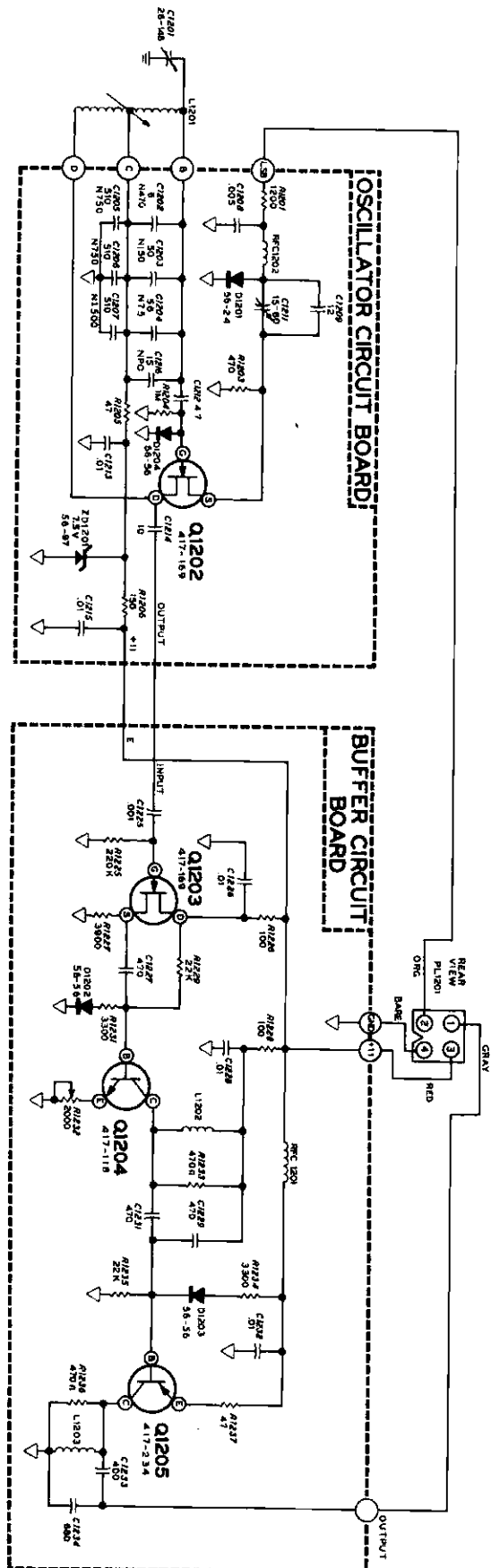

DC VOLTAGES

TRANSMITTER VOLTAGES (±20%)

NOTES:

1. BANDSWITCH IN 3.5 POSITION
2. MODE SWITCH IN TUNE POSITION
3. METER SWITCH IN PWR POSITION
4. MIC/CW-LEVEL FULLY COUNTERCLOCKWISE

○ DC VOLTAGE IN RECEIVE OR TRANSMIT MODES

VFO Filter Circuit Board

TROUBLESHOOTING CHART

SYMPTOM	POSSIBLE CAUSE
Premix signal low all bands (VFO missing).	<ol style="list-style-type: none"> 1. L1251, L1252, L1253. 2. C1251, C1253, C1254, C1255. 3. Q1251.

X-RAY VIEW

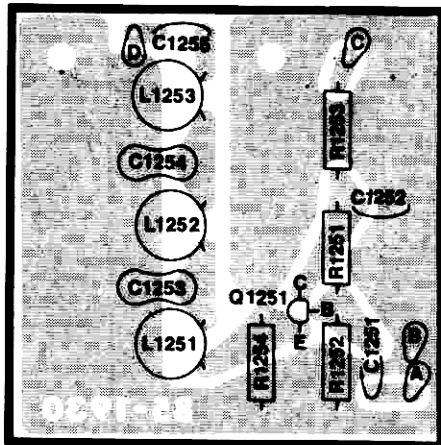

(Shown from component side)

VOLTAGE CHART

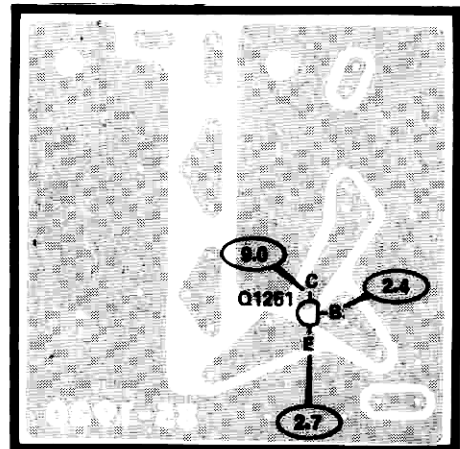

(Shown from component side)

NOTE: Heath part numbers that correspond to the circuit component numbers will be found in the Parts List starting on Page 1-73 of the Assembly Manual.

CIRCUIT DESCRIPTION

An emitter-follower stage (Q1251) and a low pass filter formed by L1251, L1252, L1253, C1253, and C1254 comprise the VFO filter.

This filter prevents spurious premix products from entering the receiver injection circuits.

SCHEMATIC

Refer to Page 2-46 for Schematic Notes.

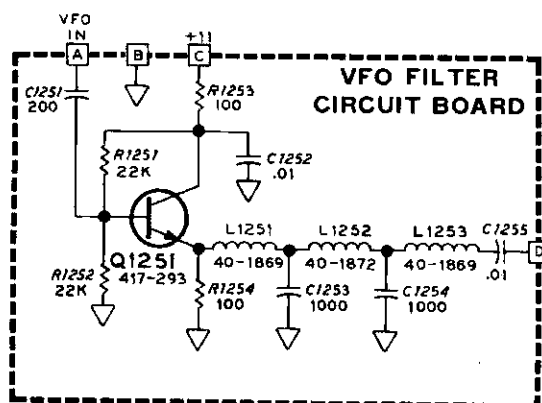

Converter Circuit Board

TROUBLESHOOTING CHART

SYMPTOM	POSSIBLE CAUSE
Output voltage low.	<ol style="list-style-type: none">1. Q851, Q852, T851.2. 5 volt input low.
No output voltage.	<ol style="list-style-type: none">1. No input voltage.2. Q851, Q852, T851.3. D851 – D854.4. C851 – C857.5. Solder bridge on board.

X-RAY VIEW

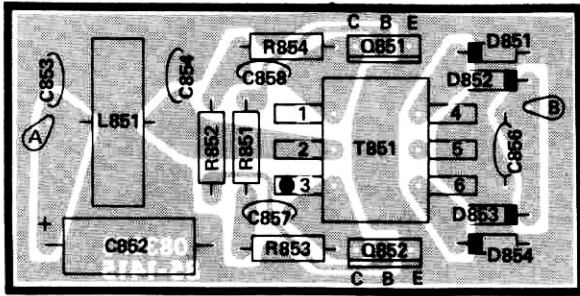

(Shown from component side)

VOLTAGE CHART

(Shown from component side)

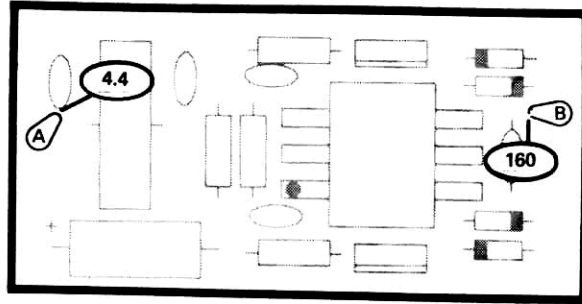

TRANSMITTER VOLTAGES ($\pm 20\%$)

NOTES:

1. BANDSWITCH IN 3.5 POSITION
2. MODE SWITCH IN TUNE POSITION
3. METER SWITCH IN PWR POSITION
4. MIC/CW-LEVEL FULLY COUNTERCLOCKWISE

○ DC VOLTAGE IN RECEIVE OR TRANSMIT MODES

NOTE: Heath part numbers that correspond to the circuit component numbers will be found in the Parts List starting on Page 1-55 of the Assembly Manual.

CIRCUIT DESCRIPTION

The converter consists of an oscillator, formed by Q851 and Q852, T851, and associated feedback components. This circuit oscillates at approximately 25 kHz, and the high voltage on the secondary of T851 is rectified by D851 through D854 to produce the required 180 VDC. L851 and

the associated capacitors filter the 25 kHz switching noise off of the input line. The converter is enclosed in a shield box to prevent the harmonics of 25 kHz from interfering with the operation of the remainder of the Transceiver.

SCHEMATIC

Refer to Page 2-46 for Schematic Notes.

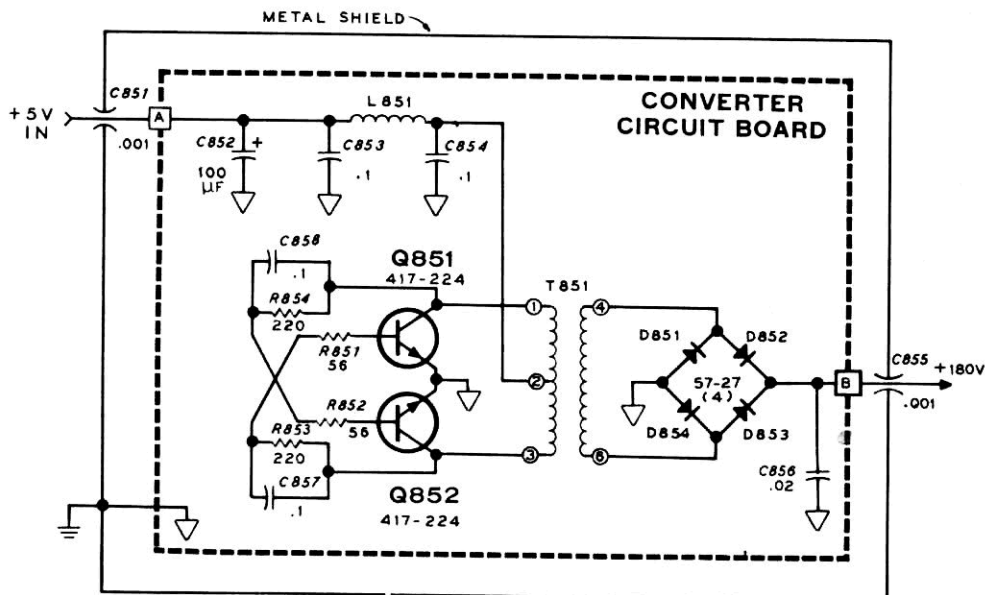

Display Circuit Board

NOTE: The Schematic for this circuit board is in the Illustration Booklet on Page 11.

TROUBLESHOOTING CHART

SYMPTOM	POSSIBLE CAUSE
In one digit, one segment brighter than others.	The associated segment driver IC.
One segment will not light.	<ol style="list-style-type: none">1. Defective display tube.2. Associated segment driver IC.3. Tube pin mounting sockets.
Display will not light.	<ol style="list-style-type: none">1. 5V or 180V missing.2. Segment driver.3. Display tube.
Display incorrect.	<ol style="list-style-type: none">1. Signal from counter board.2. Wiring error between counter and display boards.
Display erratic on 29.5 MHz band.	<ol style="list-style-type: none">1. Check 13.8 V supply.2. Check alignment of L309, L310, L319, and L320.3. Increase VFO level a small amount until the display becomes stable.

X-RAY VIEW

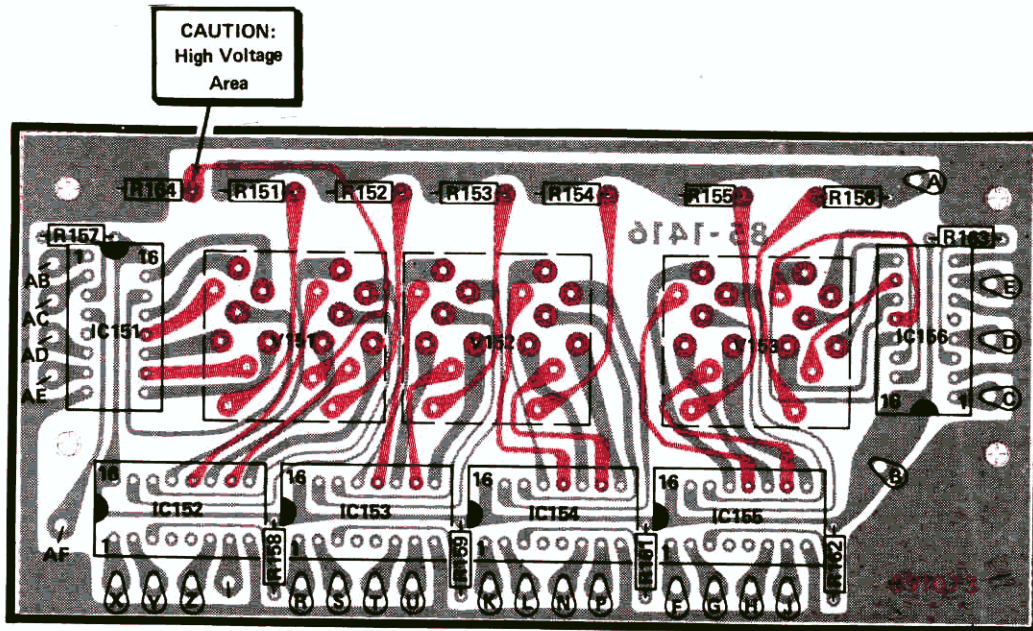

(Shown from component side. Foil on component side is shown in red).

VOLTAGE CHART

(Shown from printed side)

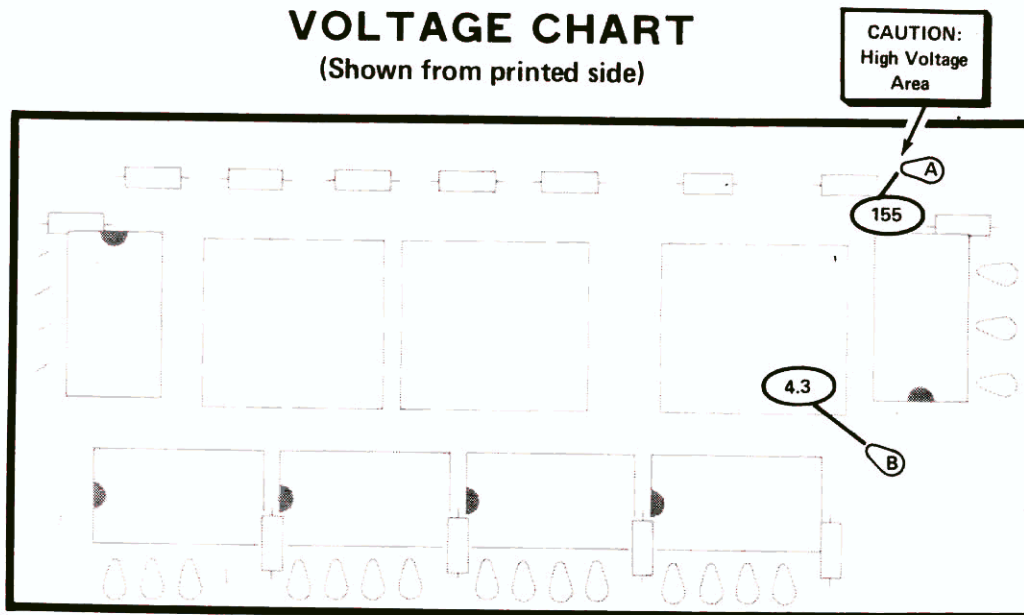

NOTE: Heath part numbers that correspond to the circuit component numbers will be found in the Parts List starting on Page 1-55 of the Assembly Manual.

TRANSMITTER VOLTAGES ($\pm 20\%$)

NOTES:

1. BANDSWITCH IN 3.5 POSITION
2. MODE SWITCH IN TUNE POSITION
3. METER SWITCH IN PWR POSITION
4. MIC/CW-LEVEL FULLY COUNTERCLOCKWISE

○ DC VOLTAGE IN RECEIVE OR TRANSMIT MODES

CIRCUIT DESCRIPTION

The display board receives the outputs of five memory latches (IC's 103, 105, 107, 109 and 111) from the counter board (A). The four BCD outputs of each memory latch are processed by a segment driver so the appropriate segments of its display tube are turned on. The first display digit has a segment driver (IC156) which is controlled by the Band switch. This digit is in the megahertz position and is blank, or reads 1 or 2, as appropriate.

The schematic diagram shows segment driver outputs A through G, which drive similarly lettered segments of the display tubes. The driver output voltages for lighted segments are lower than the voltages for unlighted tube segments. Each tube requires an anode voltage of 180 VDC, which is supplied by the converter from its 5 VDC input. This is the only high voltage used in the Transceiver.

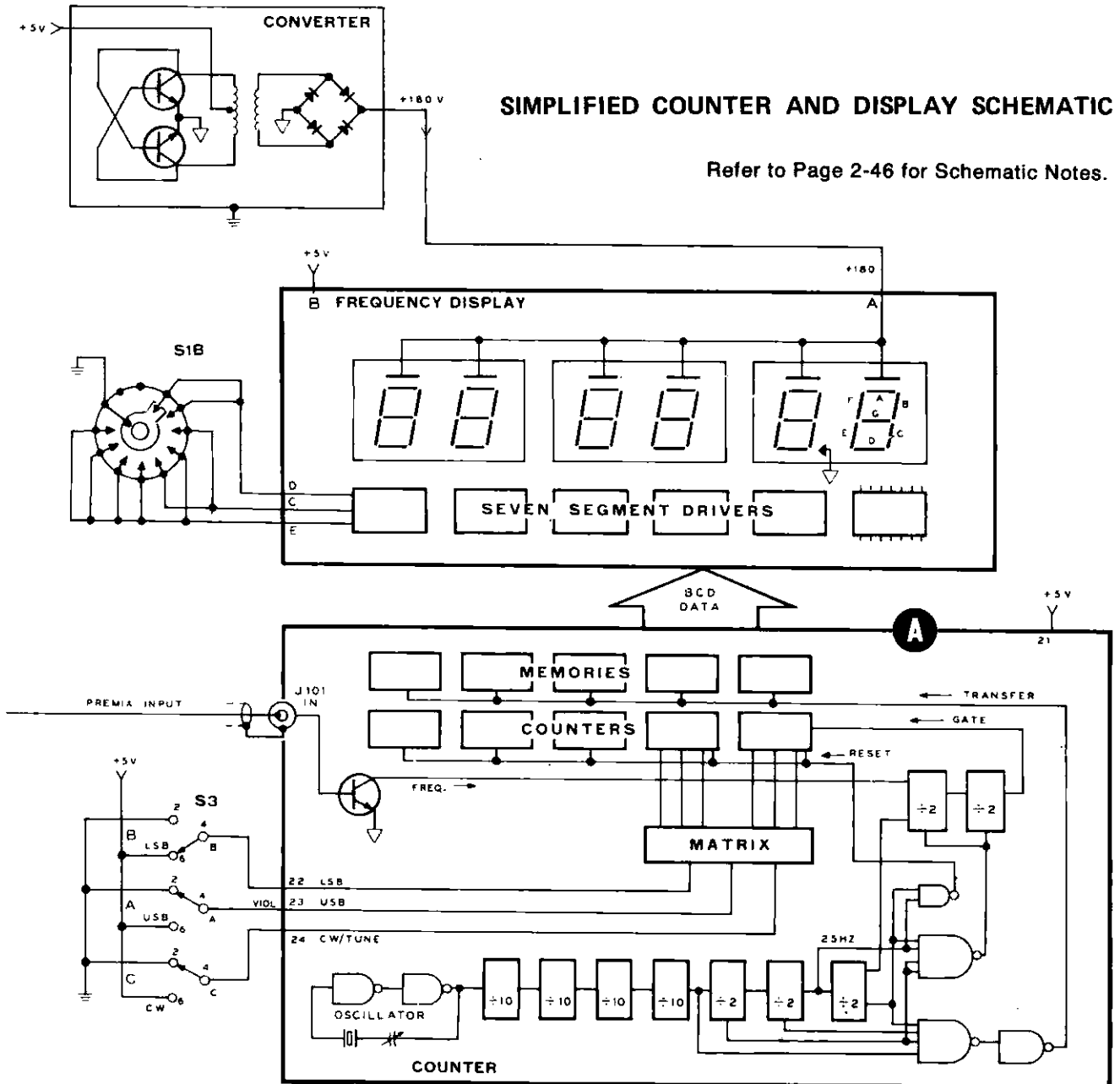

1. BAND SWITCH AT 3.5MHZ POSITION.
2. ENCIRCLED LETTERS ON PLUG-IN BOARDS REFER TO UNDER-CHASSIS LABELS.

Counter Circuit Board

NOTE: The Schematic for this circuit board is in the Illustration Booklet on Page 11.

TROUBLESHOOTING CHART

SYMPTOM	POSSIBLE CAUSE
Readout of preset frequencies incorrect (6606.4, 6603.6, 6604.3)	<ol style="list-style-type: none">1. Time base not running.2. IC-112 thru IC-119.3. 5V missing.
One digit incorrect.	<ol style="list-style-type: none">1. Associated counter IC.2. Associated memory IC.3. Display board connections.4. Chassis wiring.
Will not count (preset frequency display OK).	<ol style="list-style-type: none">1. Premix signal missing or low in voltage.2. Q101.3. IC101.

CIRCUIT DESCRIPTION

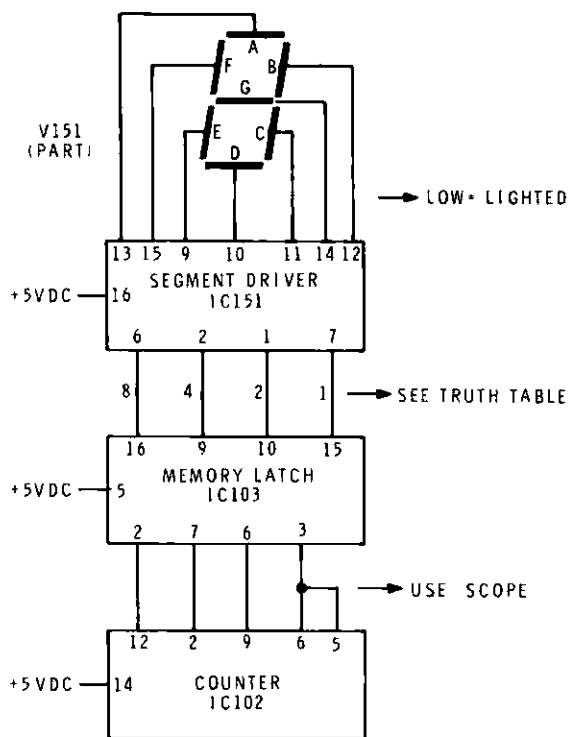

VALUE	MEMORY LATCH PINS			
	16	9	10	15
0	L	L	L	L
1	L	L	L	H
2	L	L	H	L
3	L	L	H	H
4	L	H	L	L
5	L	H	L	H
6	L	H	H	L
7	L	H	H	H
8	H	L	L	L
9	H	L	L	H

L = LESS THAN 0.8VDC
 H = MORE THAN 1.5VDC

MEMORY LATCH TRUTH TABLE

Figure 4-3

The function of this card is to count the premix signal (the difference frequency of the mixed HFO and VFO signals) and to place the count in the proper format for display. Figure 4-3 shows a counter memory latch, segment driver and display tube chain. The truth table for the memory latch output pins is included.

The premix signal is amplified by Q101 and applied to prescaler IC101, which divides the input signal by four. This division is necessary to reduce ambiguity and flicker in the last (100 Hz) digit of the display, and to insure that the counters will be operating below their maximum frequency limit.

A stable crystal oscillator (IC112A, 112B and Y101) is used as a 1 MHz time base. Six integrated circuits (IC113 through IC118) form a divider string whose 100 Hz, 50 Hz, 25 Hz, and 12.5 Hz outputs are applied to IC's 119A, 119B and 112C to produce the gate, reset and transfer pulses. The gate pulse controls the length of time the counter will accept the input signal for counting. The transfer pulse allows the data in the counter to enter the memory latches, and the reset pulse resets the counters and prescalers.

As the premix signal is above the signal frequency by an amount equal to the BFO frequency, the presettable decade counters are programmed to start counting from a preset number below zero by the amount of the BFO frequency. To calculate this preset number, the BFO frequency is subtracted from 10,000.0 kHz, which is used as an "arbitrary zero." See Figure 4-4. It is convenient to use 10,000.0 kHz as the false zero because the counters use only five digits of the display and the "1" will not be seen.

An example follows for a 3900 kHz LSB signal:

If the counter IC's are preset at 6606.4 kHz and the premix signal frequency of 7293.6 kHz is counted, the total for

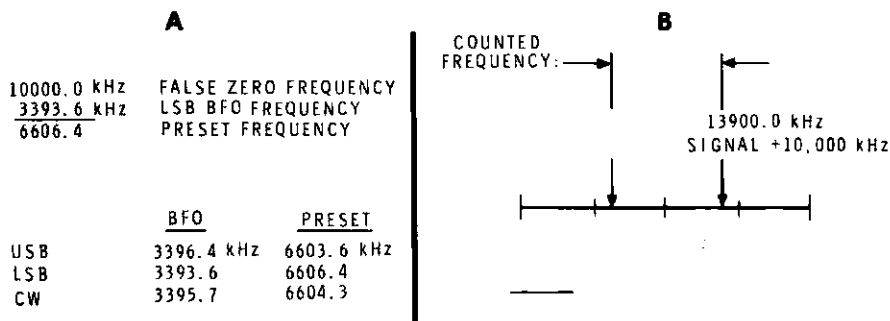
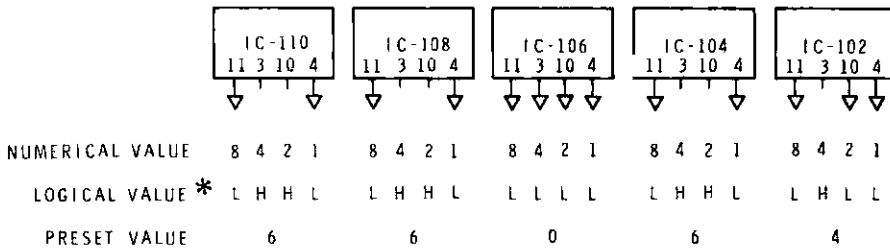

Figure 4-4



LOWER SIDEBAND PRESET.

Figure 4-5

* L=LOW H=HIGH, LOWS NOT SIGNIFICANT. TOTAL OF HIGH VALUES EQUAL PRESET VALUE.

display is 13900.0 kHz as shown in Figure 4-4. However, as there is no provision for displaying the figure "1," the display will read 3900.0, which is the correct signal frequency. The following tabulation shows the calculations:

HFO for 3.5 MHz band	12395.0 kHz
VFO	<u>5101.4</u>
Premix	7293.6 kHz
False zero	10000.0 kHz
BFO for LSB	<u>3393.6</u>
Preset	6606.4 kHz
Preset frequency	6606.4 kHz
Counted frequency (Premix)	<u>7293.6</u>
Display (Signal) frequency	*13900.0 kHz

*The signal frequency will be displayed as "3900," as the "1" cannot be seen.

NOTE: The first of the six display digits is controlled by the BAND switch and is blank, 1, or 2 as appropriate. This discussion deals only with digits two through six, controlled by the counter IC's.

BCD (binary-coded decimal) is used to program each counter IC for a preset frequency at pins 11, 3, 10, and 4 (which have decimal values of 8, 4, 2, and 1). If any of these pins is grounded, it is logically low, and if not connected or positive, it is logically high. Only the high pins are significant. The values of the highs, if any, at the pins of each IC are added together to determine the preset number for that IC. Refer to Figure 4-6, the schematic diagram, and the following explanation of how the counter IC's are programmed for the LSB preset frequency of 6606.4 kHz.

IC110: Pins 11 and 4 are grounded and therefore have no value. Pins 3 and 10, with values of 4 and 2 respectively, are not connected and are therefore high, so the figures are significant. 4 + 2 = 6 as the preset value for this IC.

IC108: Same as IC110.

IC106: All pins are grounded and are therefore low, so the preset value is 0.

IC104: Pin 11 is grounded directly and pin 4 is grounded through R107, so there is no value at these pins. When the front panel LSB button is pushed, a positive voltage is connected to pin 22 of counter circuit board A. This voltage is applied to the anodes of D105 and D102, which causes them to conduct and pass the voltage to pins 3 and 10 of the IC. These pins are therefore high and have values of 4 and 2, so the preset value of the IC is 6.

IC102: Pin 11 is grounded directly, and pins 10 and 4 are grounded through R105 and R104, so these pins are low and without value. The positive LSB voltage is applied through D109 to pin 3, which becomes high and has a value of 4. The preset value for this IC is therefore 4.

The presets for the second, third and fourth digits of the display are fixed as "660" (IC's 110, 108 and 106). The remaining two digits change as the USB, LSB, and CW buttons apply positive voltages through the diode matrix to the pins of IC104 and IC102. The USB preset frequency will be 6603.6 because the positive voltage from pin 23 of board A will be applied to IC104 pins 10 and 4, total value 3, and IC102 pins 3 and 10, total value 6. The CW preset frequency will be 6604.3 because the positive voltage will be connected from pin 24 of board A to IC104 pin 3, value 4, and to IC102 pins 10 and 4, total value 3.

IC's 103, 105, 107, 109 and 111 are memory latches which store data from the counters during counting periods. This eliminates flashing digits which would otherwise be present during counting periods. During the transfer pulse, the BCD count present at a counter output is transferred to the memory, which retains the count at its output until the next transfer pulse.

The memory outputs are connected to the segment drivers, which are located on the display circuit board. The significant outputs are logically high. Each memory output is coded using BCD in a manner similar to the decimal coding described for presetting the counters.

X-RAY VIEW

(Shown from component side)

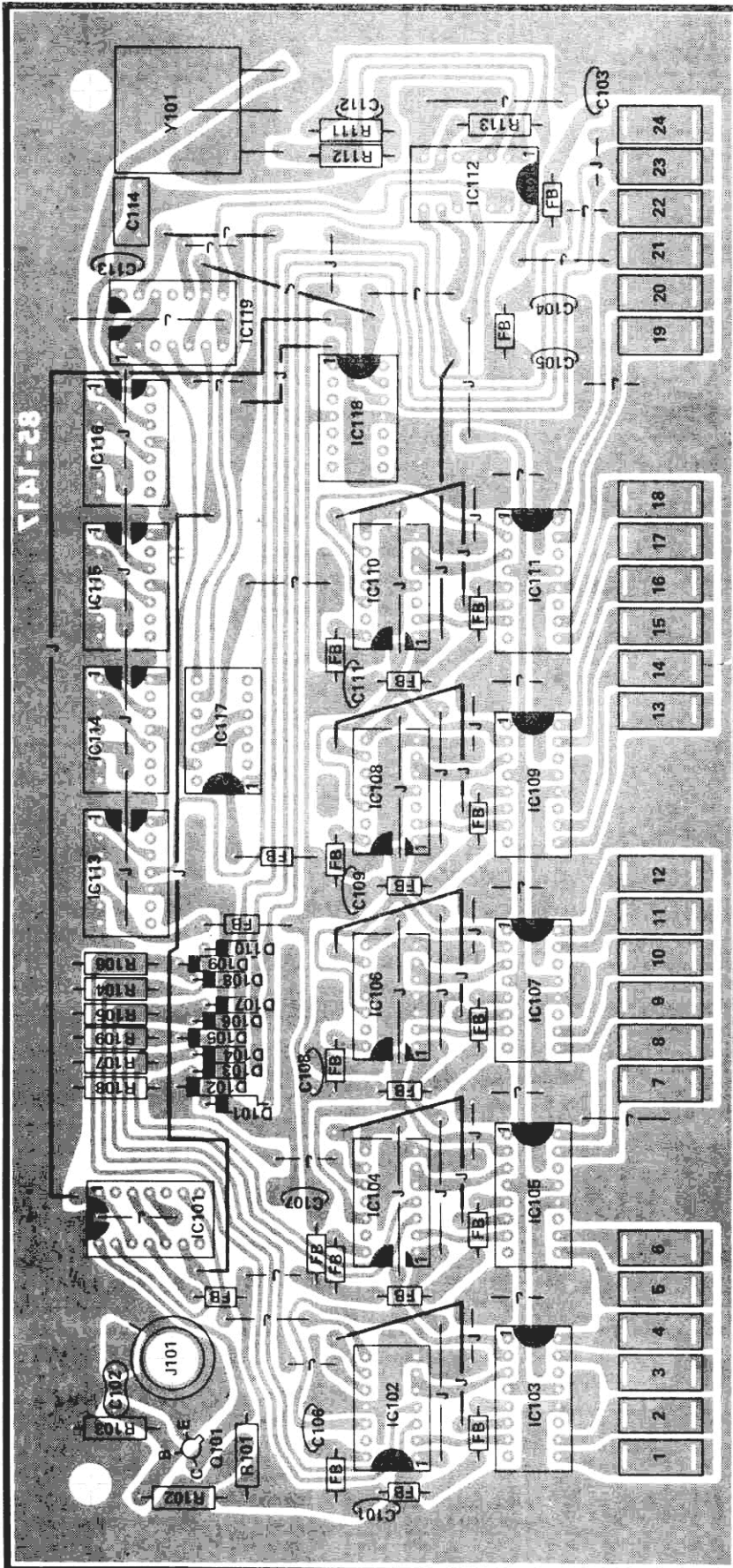

VOLTAGE CHART

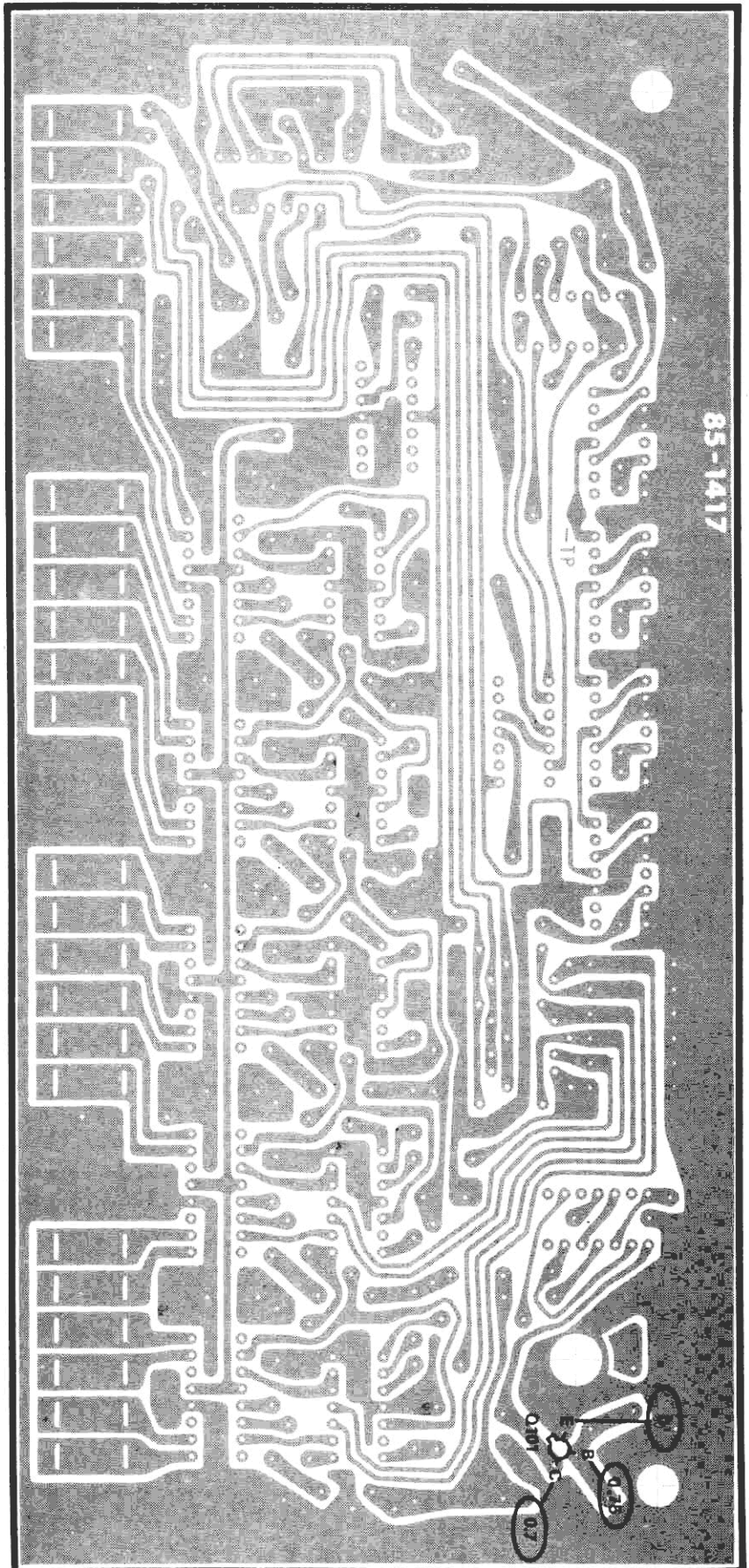

TRANSMITTER VOLTAGES ($\pm 20\%$)

NOTES:

1. BANDSWITCH IN 3.5 POSITION
2. MODE SWITCH IN TUNE POSITION
3. METER SWITCH IN PWR POSITION
4. MIC/CW-LEVEL FULLY COUNTERCLOCKWISE

 DC VOLTAGE IN RECEIVE OR TRANSMIT MODES

Transmitter Audio/Reg Circuit Board

CIRCUIT DESCRIPTION

The function of these circuits is to process the transmitter audio input, provide the transceiver T/R control functions, and regulate the 13.8 volt input voltage to 11 volts and 5 volts for use throughout the Transceiver.

IC201 is a quad-operational amplifier, (there are four op amps in one package). One section is used as a microphone preamplifier. Phone patch inputs are also processed through this stage, which is disabled in the CW and TUNE modes to prevent microphone audio from being transmitted illegally. The microphone preamplifier feeds two controls on the chassis — the MIC/CW Level and Vox Gain controls.

The wiper of the audio section of the MIC/CW Level control is connected to the second section of IC201, which provides additional gain for the transmit audio. This amplifier is disabled in the receive mode for muting purposes. Q201 is an emitter follower which provides impedance matching to the balanced modulator audio input (circuit board E).

The wiper of the Vox Gain control is connected to the third section of IC201, which drives the Vox circuitry. The front panel Vox switch enables this amplifier. The output is detected by diodes D201 and D202, and the resulting DC voltage drives the Vox switch, which consists of Q203, Q204, Q205, and Q206. Q207 is a switch for driving the chassis-mounted T/R relay, and Q208 provides for PTT operation.

The fourth section of IC201 is a sidetone oscillator. This oscillator and keying transistors Q209 and Q210 are enabled in the CW mode. The output of the sidetone oscillator is connected to the sidetone level control on the rear panel, and to the Vox amplifier, where it provides tone-keyed T/R switching in the CW mode.

IC202 is the 5-volt regulator, and IC203 is the 11-volt regulator. External chassis-mounted pass transistors (Q1 and Q2) are used with these regulators to increase the current-handling capacity.

TRANSMITTER AUDIO/REG SCHEMATIC

CIRCUIT BOARD B

Refer to Page 2-46 for Schematic Notes.

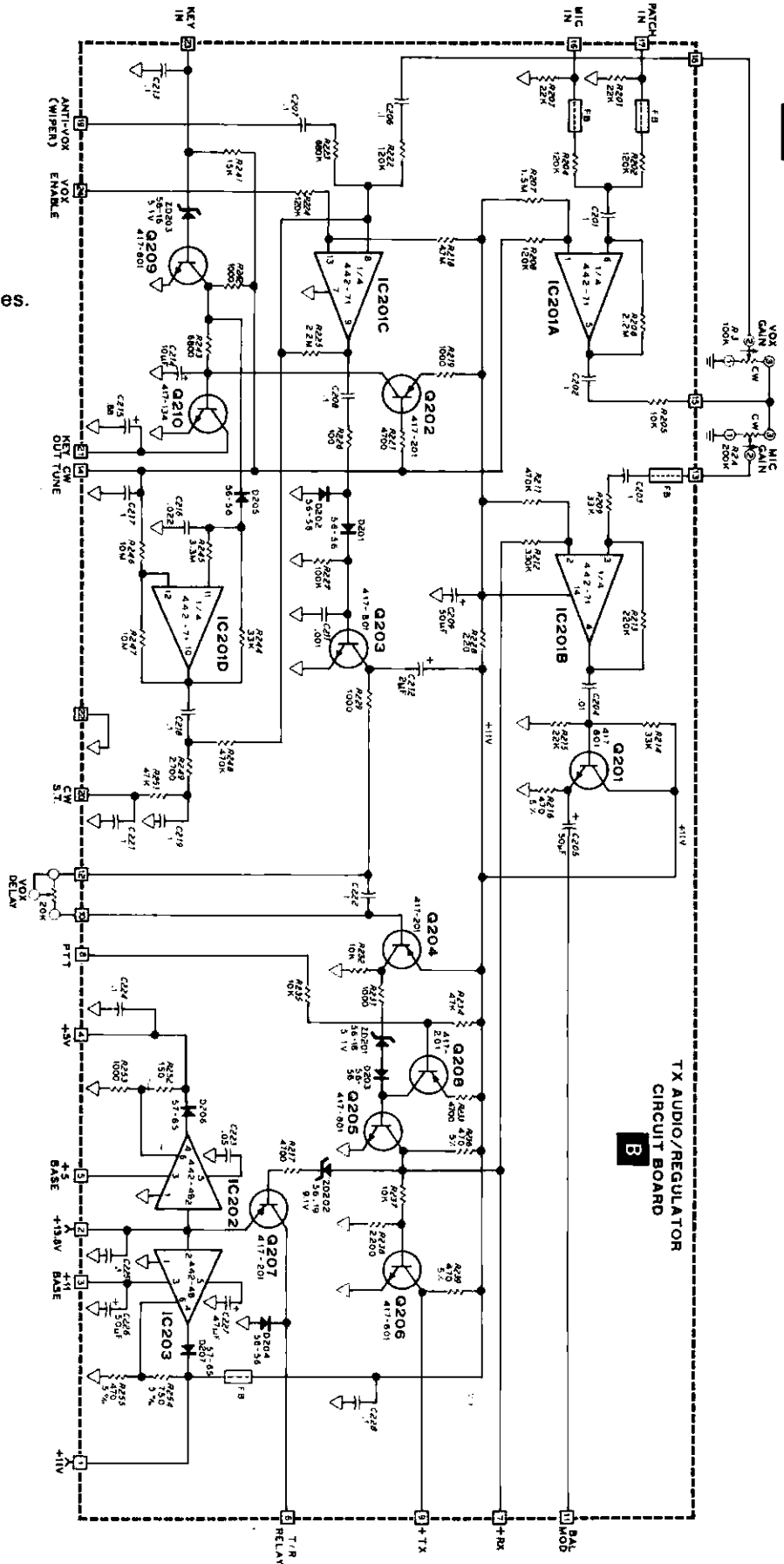

B

TROUBLESHOOTING CHART

SYMPTOM	POSSIBLE CAUSE
5V missing or low.	<ol style="list-style-type: none"> 1. 13.8V missing. 2. IC202, D206. 3. Q1 (5V source). 4. 5V line shorted.
11V missing or low.	<ol style="list-style-type: none"> 1. 13.8V missing. 2. IC203, D207. 3. Q2 (11V source). 4. 11V line shorted.
No TX audio, no VOX, no sidetone.	IC201.
No TX audio, VOX OK.	<ol style="list-style-type: none"> 1. IC201. 2. Q201. 3. Level control (Mic).
No VOX, TX audio OK, PTT OK.	<ol style="list-style-type: none"> 1. IC201. 2. VOX button not depressed. 3. Depress VOX button. 4. Q203, Q204, ZD201.
PTT inoperative.	<ol style="list-style-type: none"> 1. Q205, Q206, Q207, Q208. 2. ZD202.
Relay inoperative.	<ol style="list-style-type: none"> 1. Relay coil. 2. Q207. 3. D204. 4. ACC plug jumper. 5. Switch S3E.
No side tone, no tune mode, VOX OK.	<ol style="list-style-type: none"> 1. IC201. 2. Q209, Q210.

NOTE: Heath part numbers that correspond to the circuit component numbers will be found in the Parts List starting on Page 1-31 of this Manual.

X-RAY VIEW

(Shown from component side)

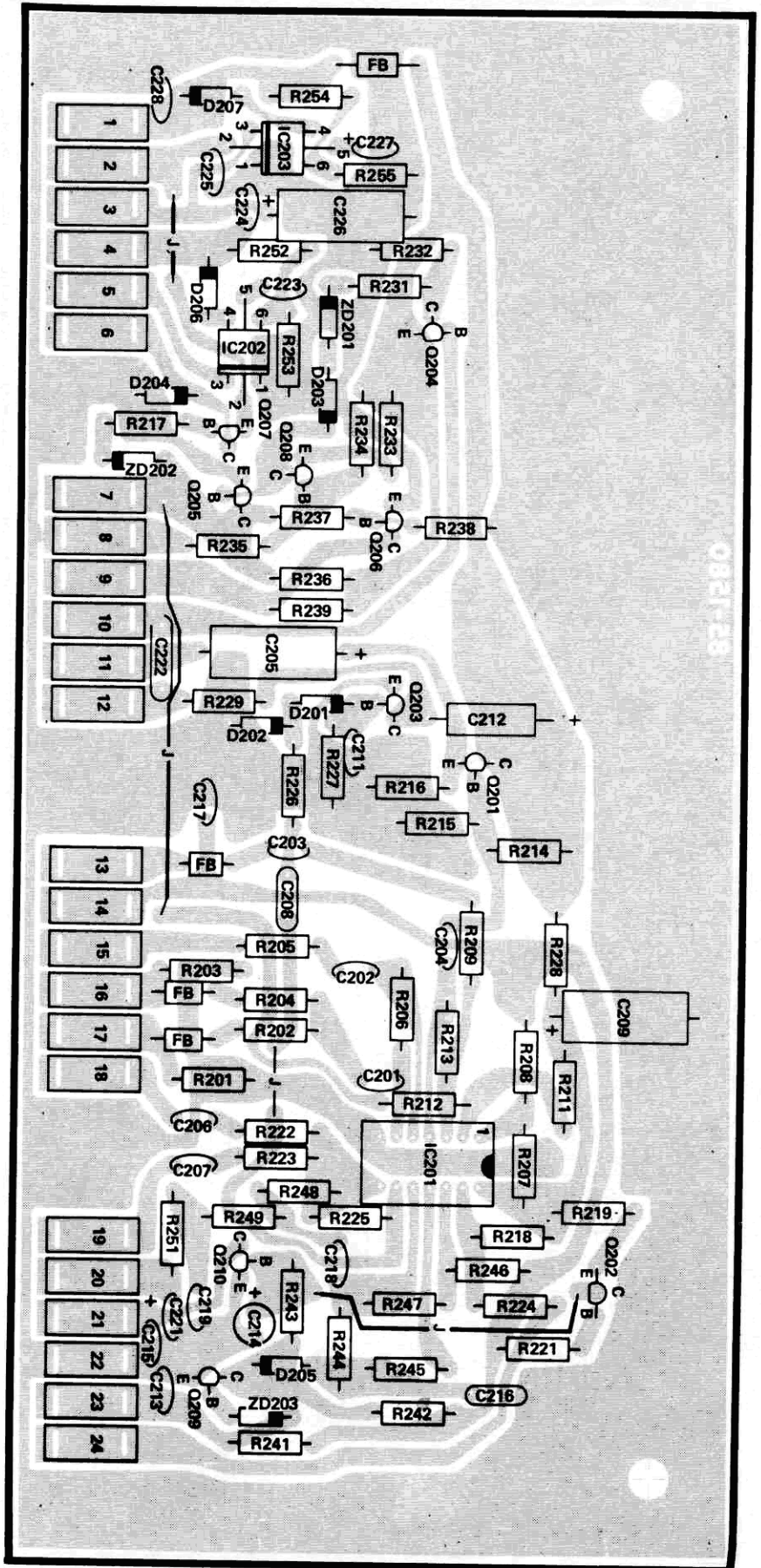

VOLTAGE CHART

(Shown from foil side)

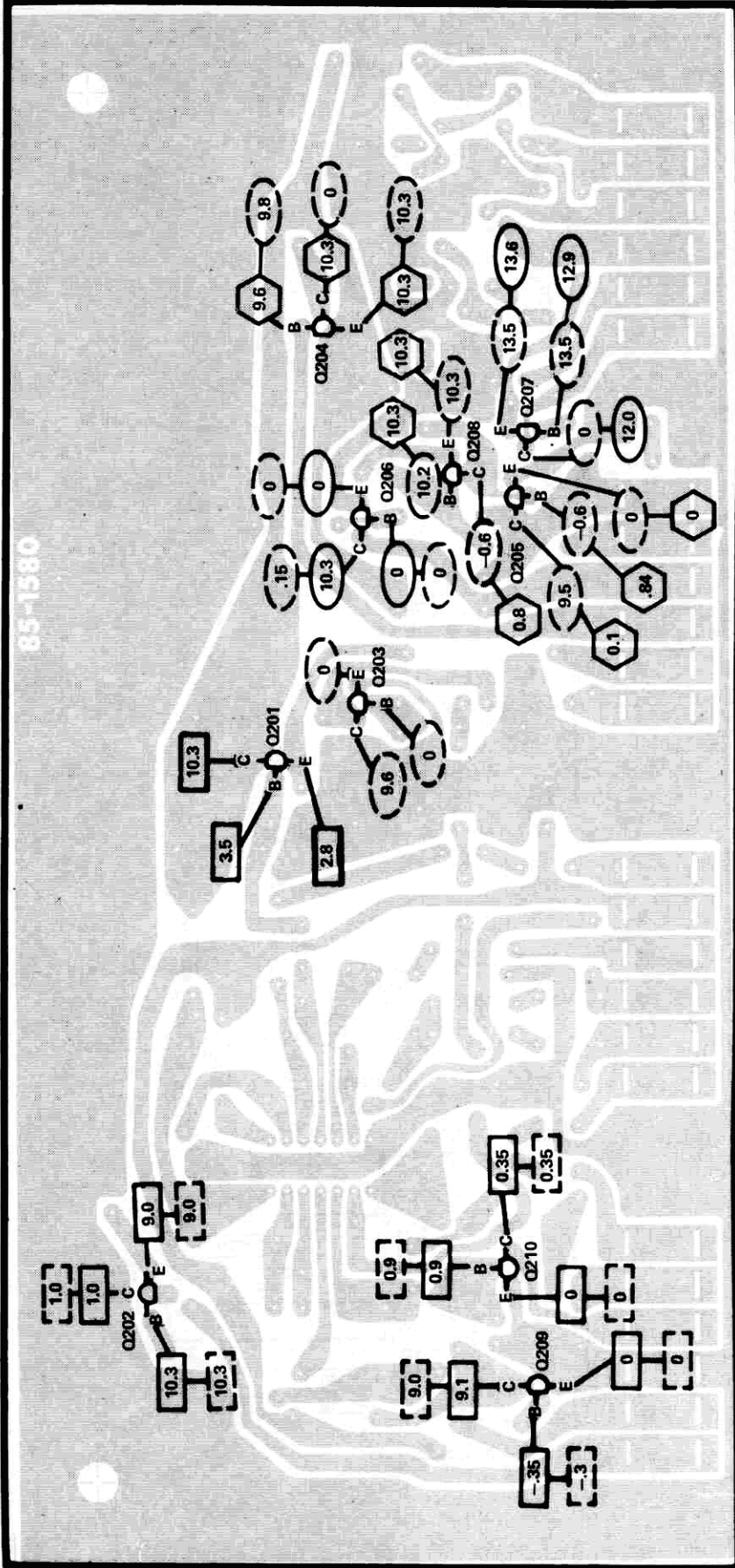

TRANSMITTER VOLTAGES (±20%)

NOTES:

1. BANDSWITCH IN 3.5 POSITION
2. MODE SWITCH IN TUNE POSITION
3. METER SWITCH IN PWR POSITION
4. MIC/CW-LEVEL FULLY COUNTERCLOCKWISE

- DC VOLTAGE WITH MODE SWITCH IN USB OR LSB POSITION
- DC VOLTAGE WITH MODE SWITCH IN MODE POSITION
- DC VOLTAGE WITH MODE SWITCH IN USB, LSB, OR CW POSITION
- DC VOLTAGE IN RECEIVE OR TRANSMIT MODES

RECEIVER VOLTAGES (±20%)

NOTES:

1. POWER SUPPLY AND 4Ω SPEAKER CONNECTED
2. ANTENNA NOT CONNECTED
3. BAND SWITCH IN 3.5 POSITION
4. RF GAIN MAXIMUM CLOCKWISE
5. AF GAIN MAXIMUM COUNTERCLOCKWISE
6. DC VOLTAGES MEASURED WITH 20 KILOHM INPUT VOM TO CHASSIS

- DC VOLTAGE WITH MODE SWITCH IN USB, LSB, OR CW POSITION

Transmitter IF Circuit Board

NOTE: This circuit board was completely instrument aligned at the factory and should not require further adjustment unless a component is replaced. If you find it necessary to replace a component in one of the tuned circuits on this circuit board, return the circuit board to the factory for alignment.

TROUBLESHOOTING CHART

SYMPTOM	POSSIBLE CAUSE
No output on any band.	<ol style="list-style-type: none"> 1. Q301, Q304, Q305, IC301. 2. 11V missing. 3. Premix missing. 4. No IF input (from card E).
No output on one band.	<ol style="list-style-type: none"> 1. Premix missing. 2. Defective component in bandpass filter or bandswitch. 3. 3.395 MHz trap misadjusted (80 meters). 4. L309, L310, L319, L320 require alignment (10 meters).
ALC inoperative (power output too low or high, no ALC meter indication).	<ol style="list-style-type: none"> 1. Q302, Q303. 2. IC301. 3. Filter/ALC (card K). 4. ALC line shorted to chassis. 5. Insufficient drive to develop ALC.

NOTE: Heath part numbers that correspond to the circuit component numbers will be found in the Replacement Parts List starting on Page 2-72 of this Manual.

CIRCUIT DESCRIPTION

The function of this circuit is to amplify the 3.395 MHz IF signal, mix it with the premix injection to the desired output frequency, and amplify this signal to the level required by the driver (circuit board J).

IC301 amplifies the IF signal. Q303 and associated components provide ALC control, which is applied to IC301 to control transmitter gain. Q302 samples the ALC voltage and drives the front panel meter to indicate ALC action. Q301 is an emitter follower, used to match the input impedance of the balanced mixer.

Diodes D306, D307, D308, and D309 form a balanced mixer, which combines the IF signal and the premix signal

to create an on-frequency transmit signal. The output of this mixer is filtered by diode-selected bandpass filters and applied to the input of the predriver.

Q304 and Q305 form the predriver circuit. Transmitter keying in CW is accomplished in this circuit by switching the emitter DC return on and off. The output of the predriver is filtered by diode-selected bandpass filters.

L321 and the 470 pF capacitor at the output form a 3.395 MHz trap, used to reduce the amplitude of a spurious output at that frequency on 80 meters.

TRANSMITTER IF SCHEMATIC

CIRCUIT BOARD C

Refer to Page 2-46 for Schematic Notes.

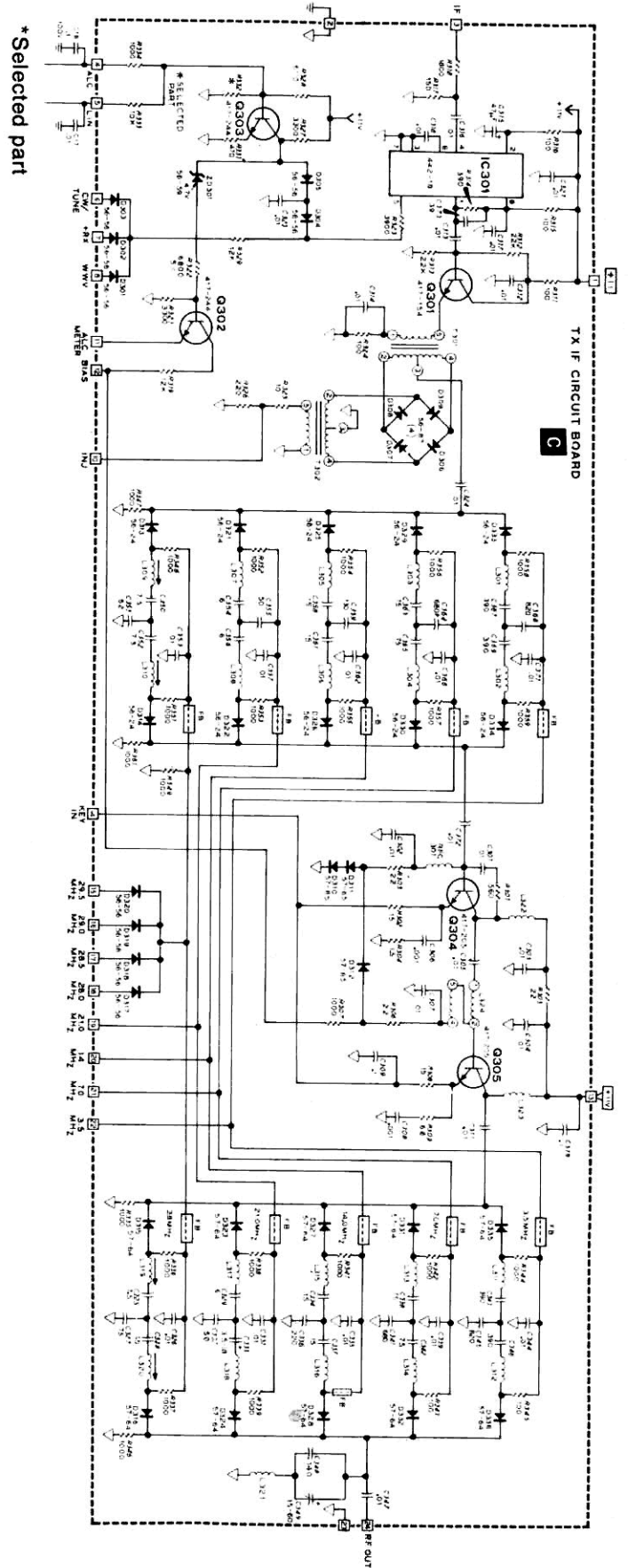



X-RAY VIEW

(Shown from component side)

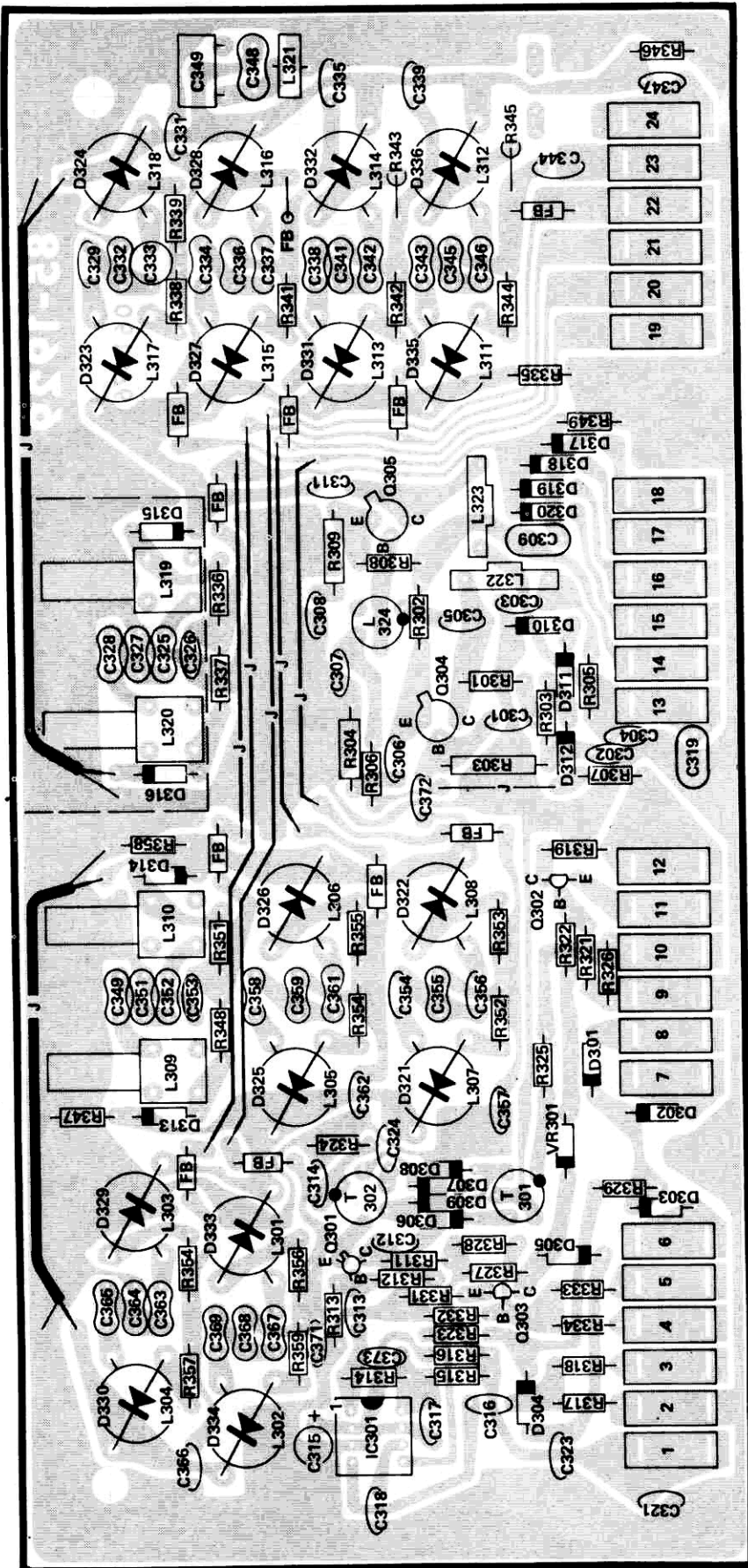



VOLTAGE CHART

(Shown from the foil side)

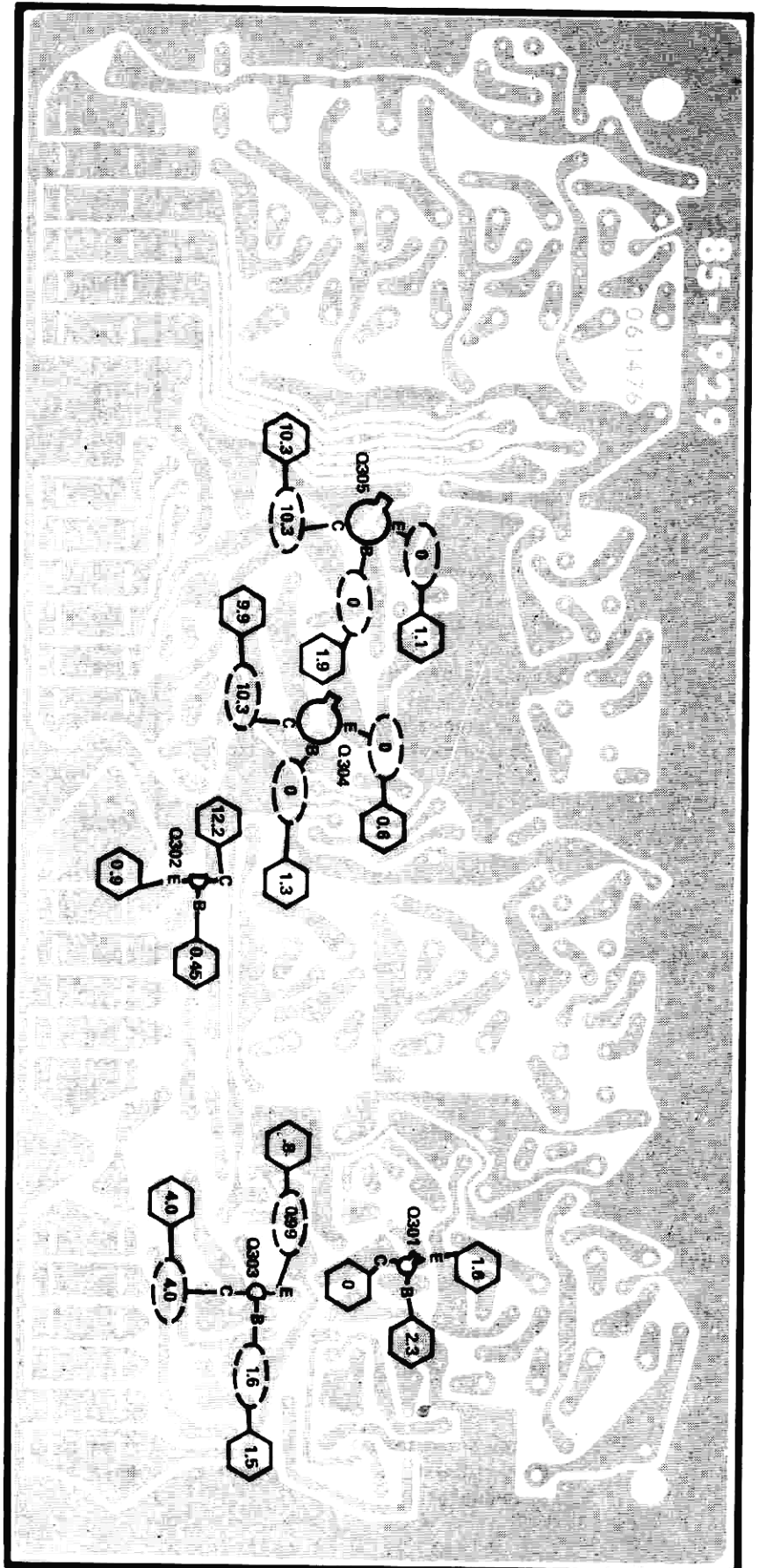

RECEIVER VOLTAGES (±20%)

NOTES:

1. POWER SUPPLY AND 4Ω SPEAKER CONNECTED
2. ANTENNA NOT CONNECTED
3. BAND SWITCH IN 3.5 POSITION
4. RF GAIN MAXIMUM CLOCKWISE
5. AF GAIN MAXIMUM COUNTERCLOCKWISE
6. DC VOLTAGES MEASURED WITH 20 KILOHM INPUT VOM TO CHASSIS*

(○) DC VOLTAGE WITH MODE SWITCH IN USB, LSB, OR CW POSITION

TRANSMITTER VOLTAGES (±20%)

NOTES:

1. BANDSWITCH IN 3.5 POSITION
2. MODE SWITCH IN TUNE POSITION
3. METER SWITCH IN PWR POSITION
4. MIC/CW-LEVEL FULLY COUNTERCLOCKWISE

(◡) DC VOLTAGE WITH MODE SWITCH IN USB, LSB, OR CW POSITION

REPLACEMENT PARTS LIST

CIRCUIT Component No.	DESCRIPTION	HEATH No.	CIRCUIT Component No.	DESCRIPTION	HEATH No.
RESISTORS			CAPACITORS		
1/4-Watt, 5%			Disc		
R325	10 Ω (brown-black-black)	6-100-12	C329, C354, C356	6 pF	21-169
R302, R308	15 Ω (brown-green-black)	6-150-12	C373	39 pF	21-167
R303, R305, R306	22 Ω (red-red-black)	6-220-12	C306, C308	.001 μF	21-140
R311, R315, R316, R324, R343, R345	100 Ω (brown-black-brown)	6-101-12	C301, C302, C303, C304, C305, C307, C311, C312, C313, C314, C316, C317, C318, C321, C323, C324, C326, C331, C335, C339, C344, C347, C353, C357, C362, C366, C371, C372	.01 μF	21-176
R317	150 Ω (brown-green-brown)	6-151-12	Mica		
R326	220 Ω (red-red-brown)	6-221-12	C325, C328,	7.5 pF	20-52
R314	390 Ω (orange-white-brown)	6-391-12	C350, C352		
R331	470 Ω (yellow-violet-brown)	6-471-12	C334, C337, C358, C361	15 pF	20-118
R301	560 Ω (green-blue-brown)	6-561-12	C332, C355	50 pF	20-97
R307, R334, R335, R336, R337, R338, R339, R341, R342, R344, R346, R347, R348, R349, R351, R352, R353, R354, R355, R356, R357, R358, R359, R361	1000 Ω (brown-red-red)	6-102-12	C327	62 pF	20-109
R318	1800 Ω (brown-gray-red)	6-182-12	C351		
R321, R327	3300 Ω (orange-orange-red)	6-332-12	C338, C342, C363, C365	75 pF	20-110
R323	3900 Ω (orange-white-red)	6-392-12	C359	130 pF	20-104
R322	6800 Ω (blue-gray-red)	6-682-12	C348	140 pF	20-189
R333	10 kΩ (brown-black-orange)	6-103-12	C336	220 pF	20-120
R319, R329	12 kΩ (brown-red-orange)	6-123-12	C343, C346, C367, C369	390 pF	20-106
R312, R313	22 kΩ (red-red-orange)	6-223-12	C341, C364	680 pF	20-134
			C345, C368	820 pF	20-171
Other Resistors			Other Capacitors		
R328	6110 Ω, 1/8-watt, 1%	2-49-11	C333	3.5-18 pF trimmer	31-71
R332	Selected		C349	15-60 pF trimmer	31-63
R304	1.5 Ω, 1/2-watt (brown-green-gold)	6-159	C309, C319	.1 μF Mylar	27-47
R309	6.8 Ω, 1/2-watt (blue-gray-gold)	6-689	C315	47 μF tantalum	25-223

CIRCUIT Component No.	DESCRIPTION	HEATH No.
INDUCTORS		
L301, L302, L303, L304, L305, L306, L307, L308, L311, L312, L313, L314, L315, L316, L317, L318 L322	7.95 μ H coil	40-1672
L323	180 μ H peaking coil (brown-gray-brown)	40-488
L324	6.8 μ H peaking coil (blue-gray-gold)	40-1653
T301, T302	10.9 μ H toroid coil Transformer	40-1049 40-1050
L309, L310, L319, L320 L321	3.95 μ H coil	40-1673
RFC301	13.2 μ H toroid coil RF choke	40-1877 45-51
	Long ferrite bead	475-10
	Short ferrite bead	475-16

DIODES

D313, D314, D321, D322, D325, D326, D329, D330, D333, D334	1N458	56-24
D301, D302, D303, D304, D305, D317, D318, D319, D320	1N4149	56-56

CIRCUIT Component No.	DESCRIPTION	HEATH No.
Diodes (cont'd.)		
D306, D307, D308, D309	FH1100	56-87
ZD301	1N750A (4.7V zener)	56-59
D315, D316, D323, D324, D327, D328, D331, D332, D335, D336	DRS-110	57-64
D310, D311, D312	1N4002	57-65

TRANSISTORS-INTEGRATED CIRCUIT

Q301	2N2369 transistor	417-154
Q304, Q305	2N3866 transistor	417-205
Q302, Q303	2N5089 transistor	417-244
IC301	MC1350P integrated circuit	442-18

MISCELLANEOUS

Shield	206-1107
Board puller	207-80
Heat sink	215-31
Spring clip	258-95
Circuit board connector	432-124
IC socket	434-230
Circuit board	85-1929-3

HFO/Premixer Circuit Board

CIRCUIT DESCRIPTION

The function of these circuits is to generate crystal-controlled injection signals, and to mix these signals with the VFO signal to obtain the premix signal.

Q401, Q402, Q403, and Q404 are used as oscillators. These oscillators are diode-selected, as are the proper oscillator crystals.

The crystal oscillator signal is amplified by Q405, and

routed to the receiver circuitry. Q406 provides additional gain, and the resulting signal is applied to the premix balanced mixer.

Diodes D427, D428, D429, and D430 form a balanced mixer, which combines the HFO and VFO signals to create the premix signal. The output of the balanced mixer is filtered by diode-selected bandpass filters, and amplified by Q407. The resulting output is used to drive the transmitter and counter circuits.

HFO PREMIER SCHEMATIC

CIRCUIT BOARD D

Refer to Page 2-46 for Schematic Notes.

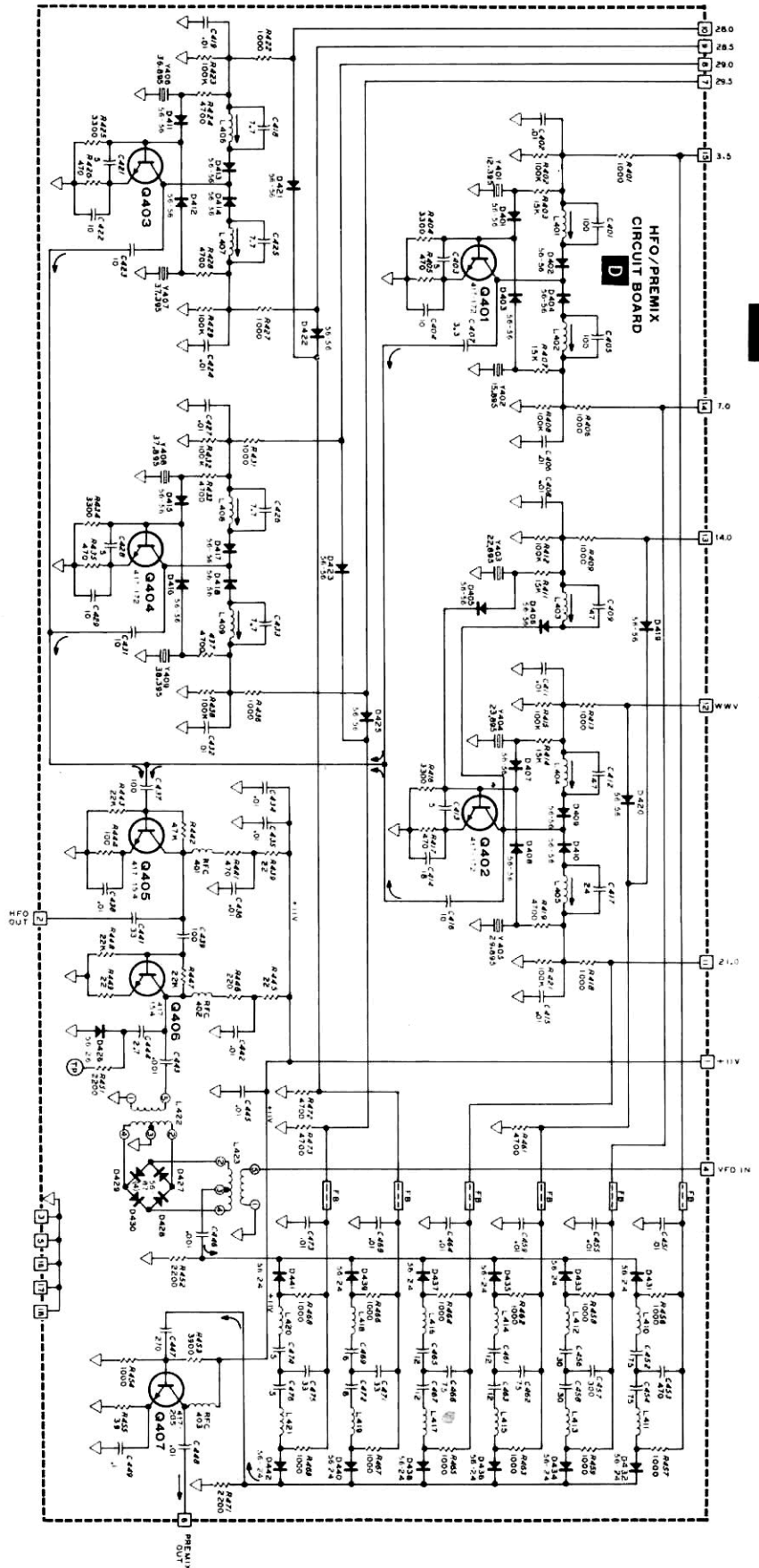

D

TROUBLESHOOTING CHART

SYMPTOM	POSSIBLE CAUSE
HFO will not oscillate or output voltage very low (all bands).	<ol style="list-style-type: none"> 1. Bandswitch wiring. 2. 11V missing. 3. Q405.
HFO inoperative, one band only.	<ol style="list-style-type: none"> 1. BAND switch. 2. For the band concerned, the associated crystal, transistor, switching diodes, coil.
Premix output low, all bands (HFO is OK).	<ol style="list-style-type: none"> 1. VFO signal low or missing. 2. Q406, Q407.
Premix output low, one band (HFO is OK).	<ol style="list-style-type: none"> 1. BAND switch. 2. Filter components associated with the band.
Premix output low, 10 meters. (HFO is OK).	VFO filter board components.

X-RAY VIEW

(Shown from component side)

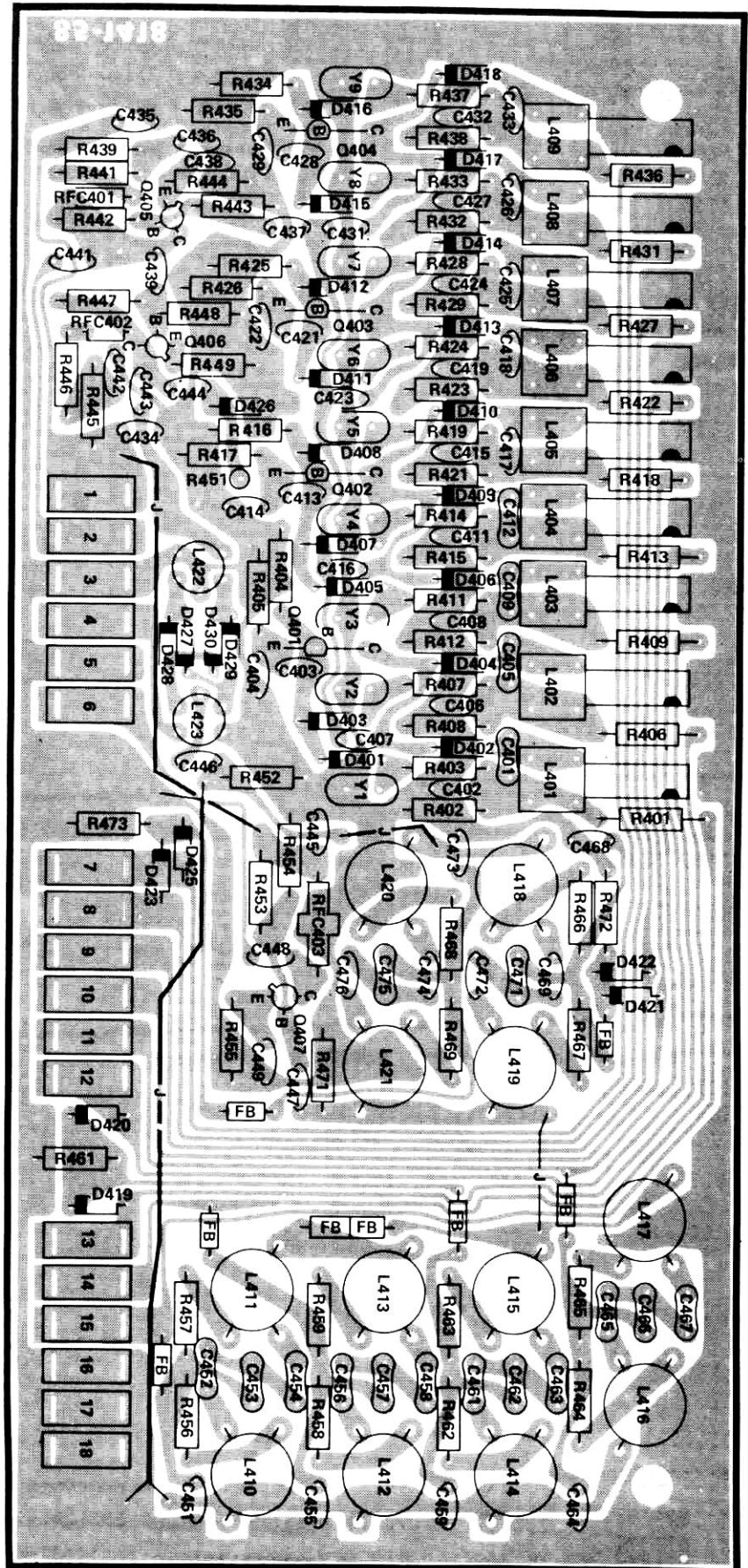

VOLTAGE CHART

(Shown from foil side)

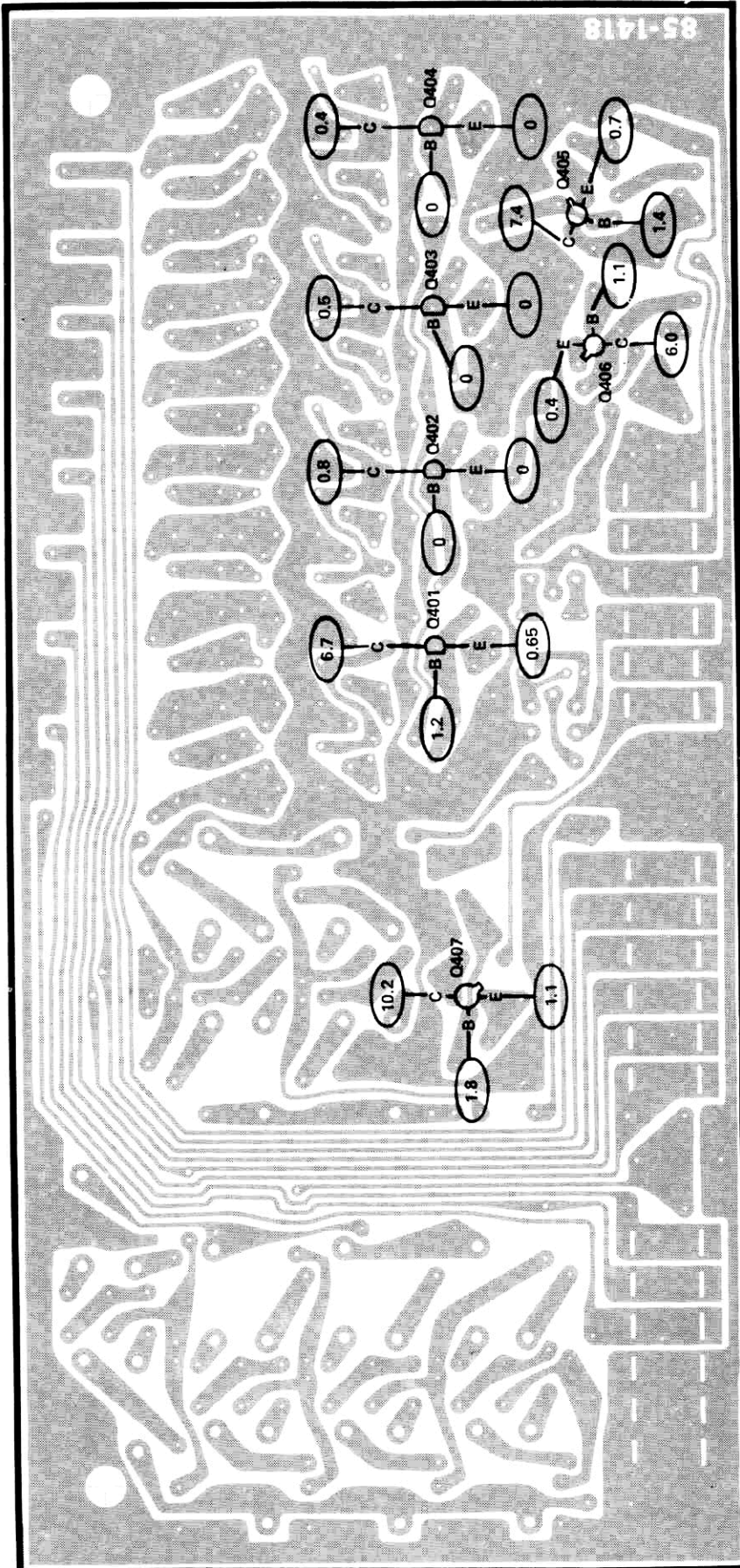

TRANSMITTER VOLTAGES ($\pm 20\%$)

NOTES:

1. BANDSWITCH IN 3.5 POSITION
2. MODE SWITCH IN TUNE POSITION
3. METER SWITCH IN PWR POSITION
4. MIC/CW-LEVEL FULLY COUNTERCLOCKWISE

○ DC VOLTAGE IN RECEIVE OR TRANSMIT MODES

Carrier Gen/Xtal

Filter Circuit Board

TROUBLESHOOTING CHART

SYMPTOM	POSSIBLE CAUSE
No output in transmit, receiver OK.	<ol style="list-style-type: none">1. Q607.2. D607, D608, D609, D611.3. Carrier Null control R665.4. T601.5. Q604, Q608.
No output in transmit CW, receiver OK.	<ol style="list-style-type: none">1. D612 not forward biased.2. CW oscillator not running. Q611, Y602.
No output in SSB transmit, receiver OK.	<ol style="list-style-type: none">1. No audio input at pin 24.2. Positive voltage at anode of D612.
Receiver and transmitter not operable, any mode.	<ol style="list-style-type: none">1. BFO's not running:<ol style="list-style-type: none">a. LSB – Q608, Y601.b. USB – Q613, Y603.c. CW – Q611, Y602.2. Q606.3. SSB filter.4. L602, L603.
Receiver inoperative, transmitter OK.	<ol style="list-style-type: none">1. Q601, Q603.
No signal in receive CW, OK in SSB.	<ol style="list-style-type: none">1. Q612.2. CW filter.3. L676, L677.4. D683 and D685 not forward biased in CW.5. D686 and D684 not reverse biased in CW.
No signal in SSB receive. Transmit OK, receive CW OK.	<ol style="list-style-type: none">1. D678 and D681 not forward biased in SSB.2. D679 and D682 not reverse biased in SSB.

CIRCUIT DESCRIPTION

These circuits provide highly selective filtering of the 3.395 MHz IF, and generate the BFO signals in both receive and transmit modes. Solid-state switching is employed to provide bilateral filtering and to select between the single sideband filter and the optional, narrow-bandwidth CW filter.

Two switches are used on each side of the crystal filters to direct the signal flow. One set of switches selects between transmit and receive paths. Transistors Q601 and Q603 are energized only in the receive mode and pass the 3.395 MHz signal from the second mixer (Q705) through the filter to the input of the receive IF board. In addition to their switching function, these stages provide impedance matching to the filter. During transmit operation, stages Q604 and Q602 serve the same function, passing the modulator output through the filter to the transmit IF board.

The second set of switches selects either the SSB filter or the CW filter. In USB or LSB modes, diodes D678 and D681 are forward biased and the SSB filter is used. Diodes D683 and D685 are back biased by current flow through D684 and D686. This blocks signal flow to the CW filter and shunts any potential "blow by" signals to ground through the .01 μ F capacitors at C681 and C686. In CW, diodes D683 and

D685 are forward biased and diodes D678 and D681 reverse biased so that signal flow is now through the CW filter. Diodes D679 and D682 shunt the SSB filter input and output to ground.

Q608, Q611, and Q613 are the beat frequency oscillators (BFO's) which provide the appropriate mixing frequency to the product detector in receive and to the balanced modulator in transmit. These three oscillators are identical except for the crystal frequency. The CW generator (Q611) is used only in the transmit mode. In receive CW, the USB generator is used to provide the offset from center frequency required to produce an audio tone from the product detector. Transistor Q609 permits the CW generator to operate only in the transmit mode, and Q612 permits the USB generator to oscillate in transmit USB or in receive USB and CW.

Four hot carrier diodes are used in the balanced modulator. The carrier generated by the appropriate BFO is amplified by transistor Q607 and is mixed with an audio signal from the transmit audio board to produce the 3.395 MHz transmit IF which is fed to the crystal filter.

CARRIER GENERATOR SCHEMATIC

CIRCUIT BOARD E

Refer to Page 2-46 for Schematic Notes.

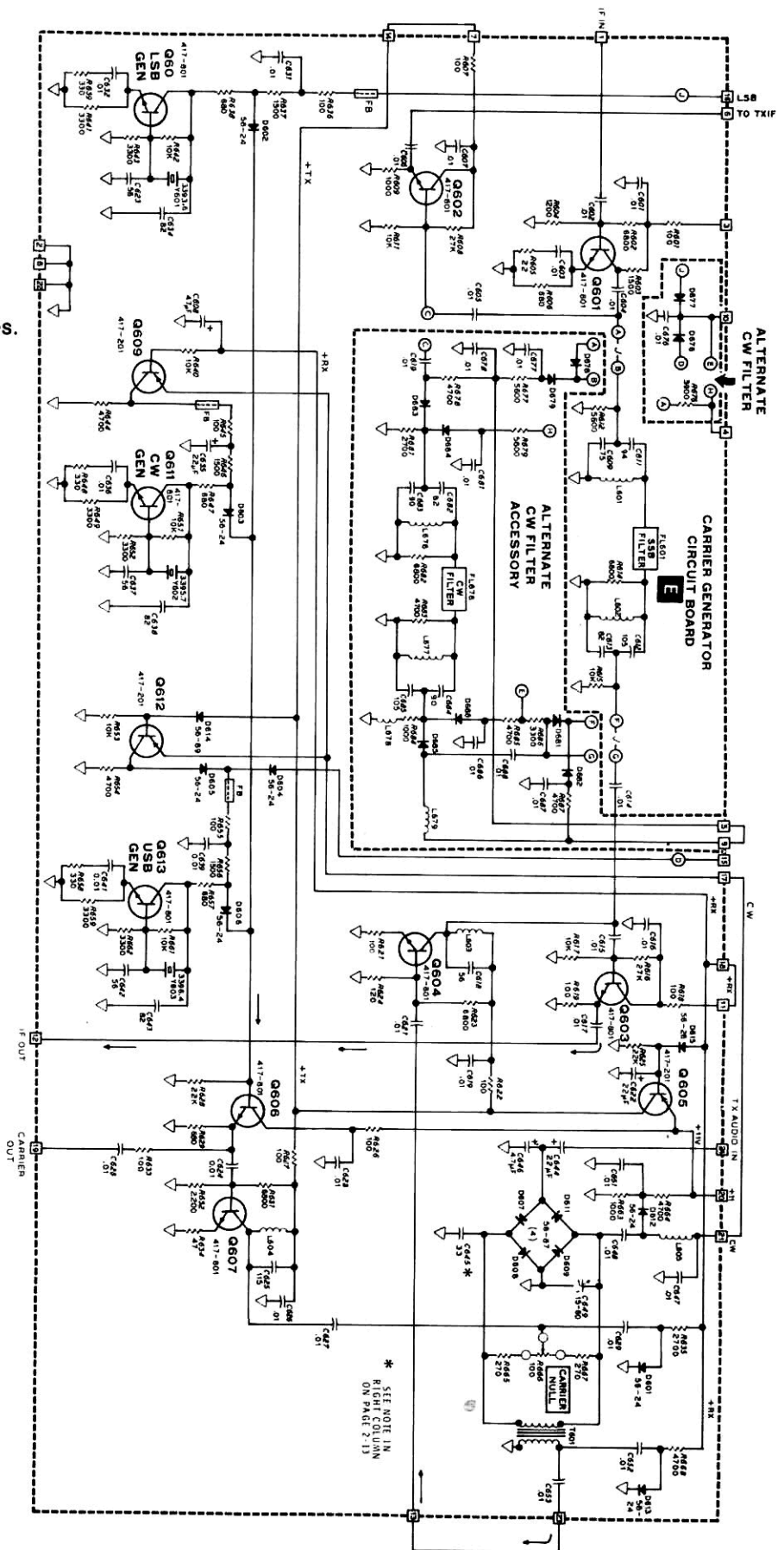

X-RAY VIEW

(Shown from component side)

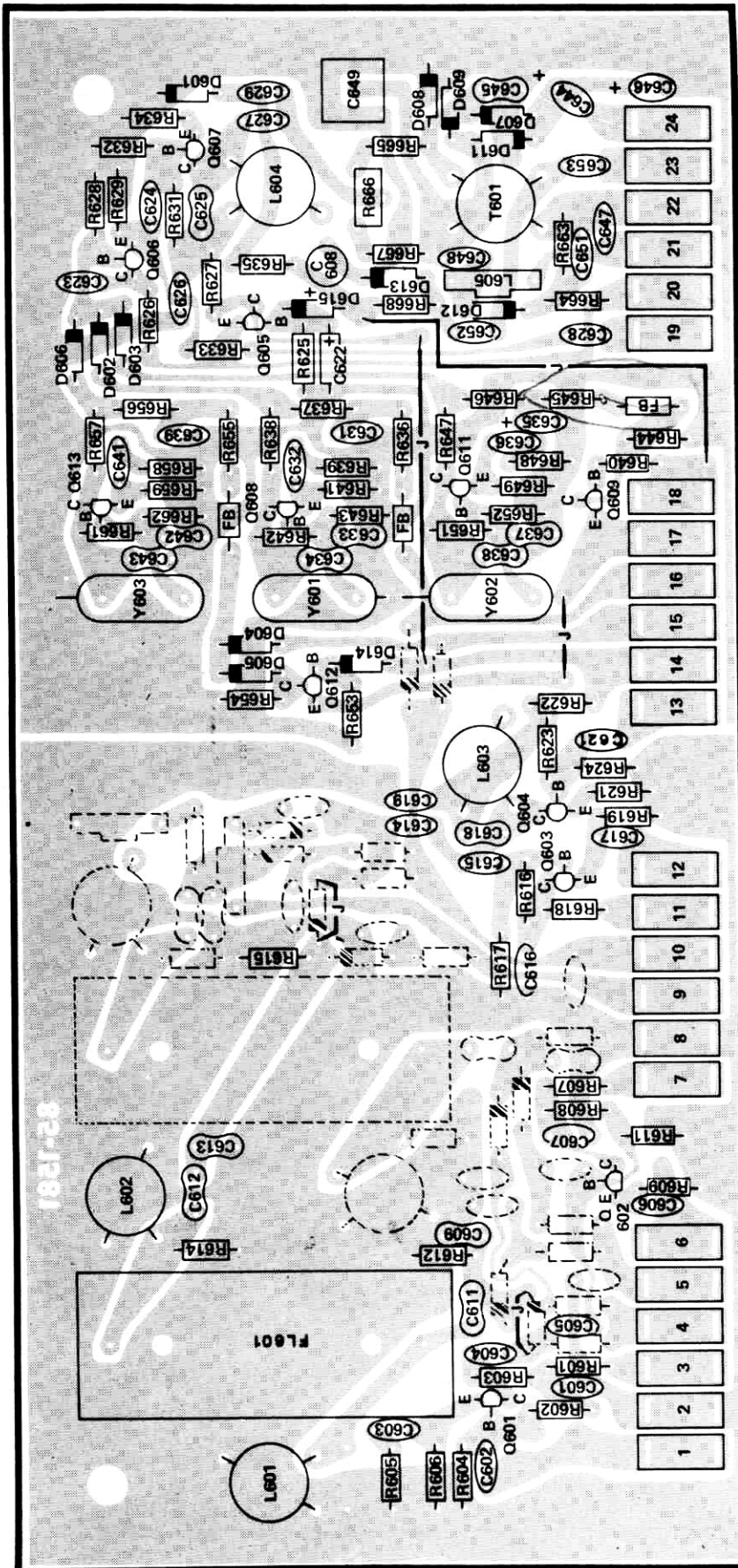

VOLTAGE CHART

(Shown from foil side)

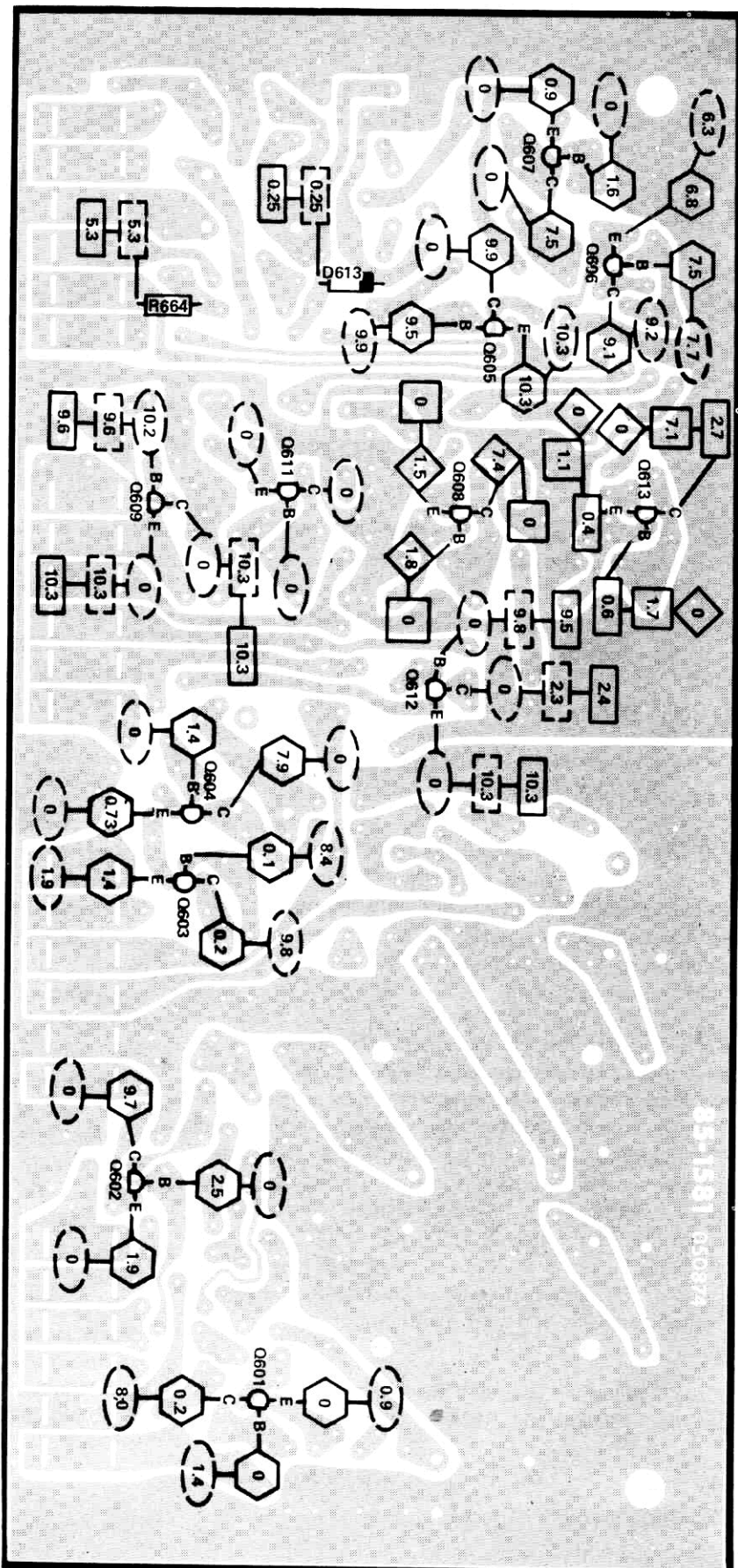

RECEIVER VOLTAGES (±20%)

NOTES:

1. POWER SUPPLY AND 4Ω SPEAKER CONNECTED
2. ANTENNA NOT CONNECTED
3. BAND SWITCH IN 3.5 POSITION
4. RF GAIN MAXIMUM CLOCKWISE
5. AF GAIN MAXIMUM COUNTERCLOCKWISE
6. DC VOLTAGES MEASURED WITH 20 KILOHM INPUT VOM TO CHASSIS

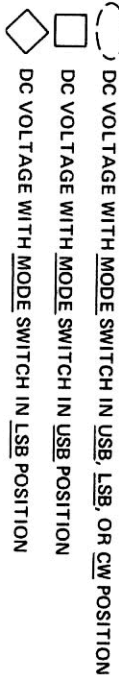

TRANSMITTER VOLTAGES (±20%)

NOTES:

1. BANDSWITCH IN 3.5 POSITION
2. MODE SWITCH IN TUNE POSITION
3. METER SWITCH IN PWR POSITION
4. MIC/CW-LEVEL FULLY COUNTERCLOCKWISE

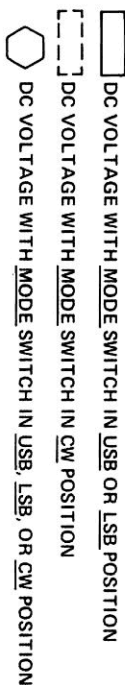

Receiver IF/Audio Circuit Board

CIRCUIT DESCRIPTION

These circuits provide 3.395 MHz IF amplification and gain control, detection, and audio amplification.

In the receive mode, a 3.395 MHz signal from board E (the crystal filter board) is fed to gate 1 of the dual gate MOSFET, Q501. The signal is amplified and passes to IC501 and Q502 where additional amplification is obtained. Emitter follower Q503 provides the power gain required to drive the product detector, automatic gain control (AGC) circuits, and the 50 ohm IF output.

The IF output level is sensed by a differential amplifier, Q504 and Q505. When the output level exceeds the threshold level, Q504 conducts and pulls the base of Q506 down on each positive peak of the IF output. Q506 conducts on each peak and places positive pulses on the base of Q507.

Q507 is an integrator which converts the pulses to a DC voltage. It has two time constants which set the attack and decay times for the AGC. R544 and C535 set the attack time constant and C535 discharges through either R546 or R545 and R546, depending on whether Fast or Slow is selected to set the decay time constant. This voltage, whose level is a function of the IF output level, is fed through the Darlington emitter follower, Q508 and Q509, where it is then applied to pin 5 of IC501 through R507 and D504. The gain of the integrated circuit is thus controlled so that the output remains relatively constant for varying input levels.

The AGC voltage is also used to drive the S-meter drive. Zener diode ZD502 and R534 set the range for S-meter

voltage which is fed through emitter follower Q512 to the front panel meter. Q511 is a DC amplifier which derives the AGC voltage for the dual-gate MOSFET. With increasing signal level, the voltage at Q509 emitter rises from approximately 4.5 to 7.0 volts. Given this input, Q511 provides (at the junction of R541 and R538) a level of from 2.0 volts to zero volts with increasing input signal. Amplified AGC voltage is applied to gate 2 of the first IF amplifier, Q501.

The IF signal is detected by a product detector formed by transformer T502 and diodes D506 through D509. Carrier injection through C522 mixes with the IF signal to produce the detected audio. After the IF is filtered out by R522, C523, and C524, the recovered audio goes to the audio bandpass filter and preamplifier. Both of these functions are accomplished in IC502, an integrated circuit made up of four operational amplifiers. The first amplifier, pins 10, 11, and 12, is used as a low pass filter. Amplifier two, pins 2, 3, and 4, is an audio amplifier. Amplifier three, pins 8, 9, and 13, is used as a high pass filter which, in cascade with the low-pass filter, sets the audio frequency response. The Volume control, between amplifiers three and four, sets the desired audio level from the front panel. After additional amplification by amplifier four (pins 1, 5, and 6), the audio signal is fed through R582 and C529 to the base of Q514. Amplifier Q514 drives a complementary output consisting of Q515, Q516, Q517, and Q518. The audio output to the speaker is taken from the collector of Q516 through C531. The frequency response of the audio amplifier is established by a feedback circuit consisting of Q513, C526, R526, R527, and C528.

RECEIVER IF/AUDIO SCHEMATIC

CIRCUIT BOARD F

Refer to Page 2-46 for Schematic Notes.

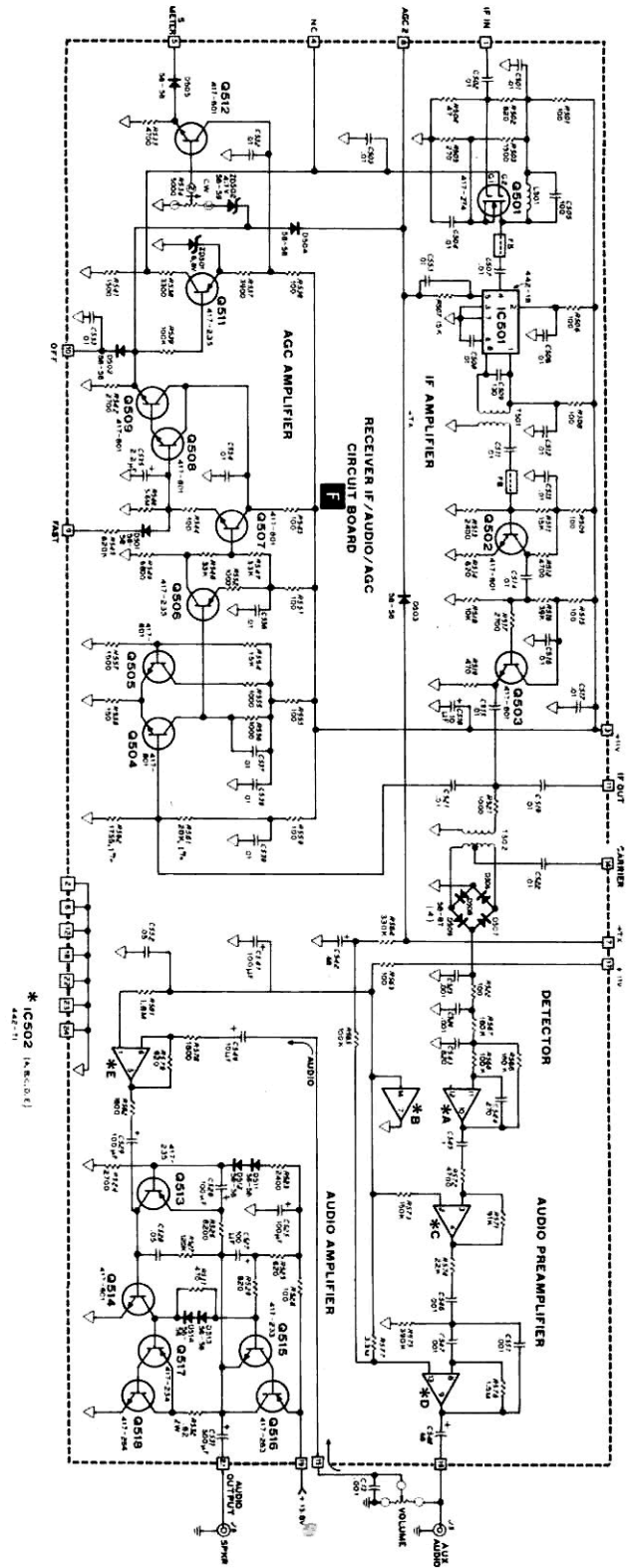

F

TROUBLESHOOTING CHART

SYMPTOM	POSSIBLE CAUSE
No Audio output.	<ol style="list-style-type: none"> 1. Q513, Q514, Q515, Q516, Q517, Q518. Check voltages. 2. IC502. 3. Positive voltage on +TX line in receive. 4. Audio Level control shorted. 5. RF Gain fully counterclockwise.
Audio distorted or weak.	<ol style="list-style-type: none"> 1. Q513 through Q518. Check voltages. 2. Insufficient carrier injection (pin 14). 3. IC502. Check voltages. 4. AGC not working. Voltage at pin 8 does not change for strong signals. 5. Q501, IC501, Q502, Q503. Check voltages. 6. D506, D507, D508, D509 defective or improperly installed. 7. T502.
No AGC.	<ol style="list-style-type: none"> 1. Q504, Q505, Q506, Q507, Q508, Q509, Q510, Q511. 2. Pin 10 grounded. 3. Coaxial jumper cable open or shorted. 4. R559 or R561 wrong value.
No S meter deflection.	<ol style="list-style-type: none"> 1. S-meter control, R534, needs adjustment. 2. No AGC. 3. AGC switch in Off position.
No IF output.	<ol style="list-style-type: none"> 1. Q501, IC501, Q502, Q503. 2. Voltage at pin 8 in excess of 6V. 3. Pin 4 at ground potential. 4. RF Gain fully counterclockwise.

X-RAY VIEW

(Shown from component side)

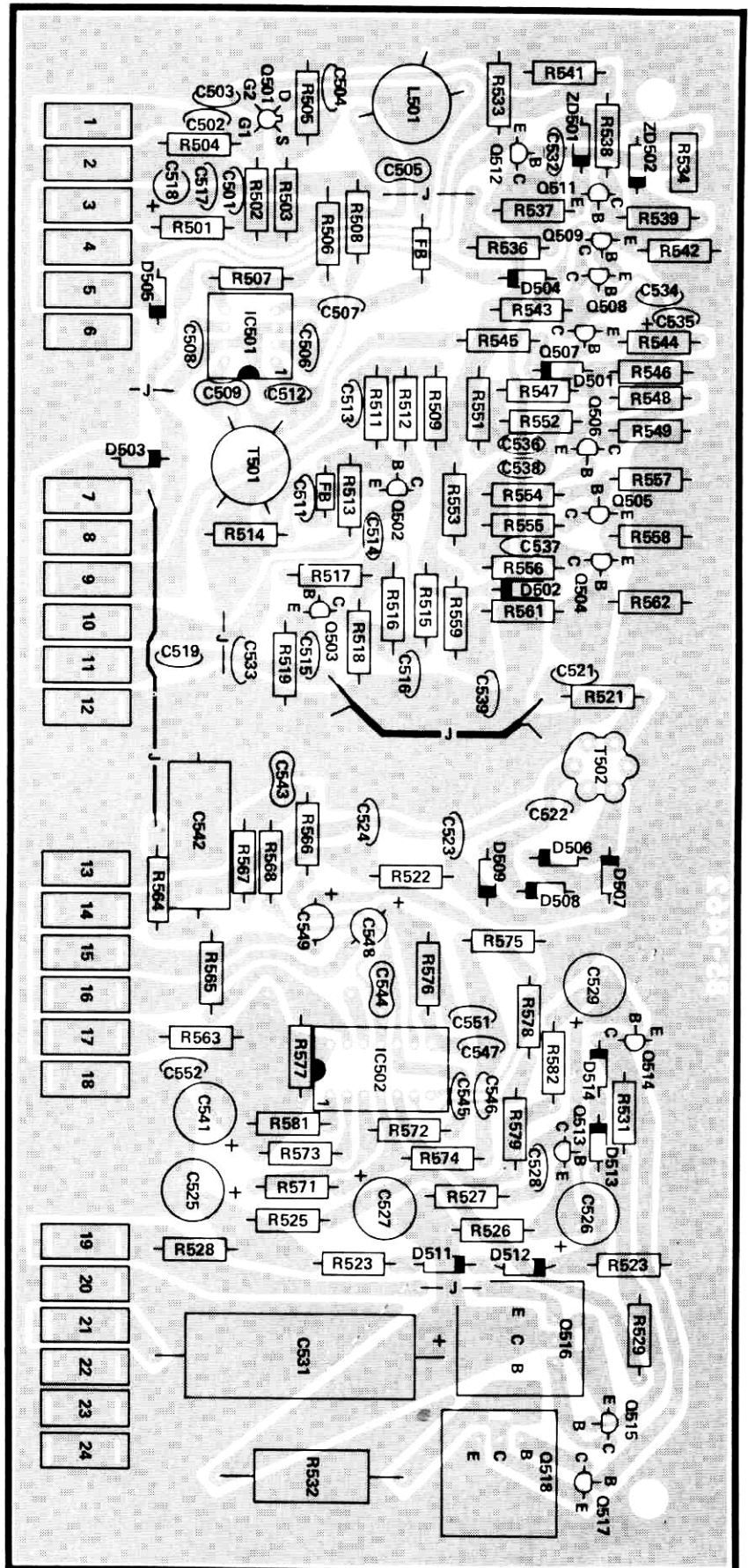

VOLTAGE CHART

(Shown from foil side)

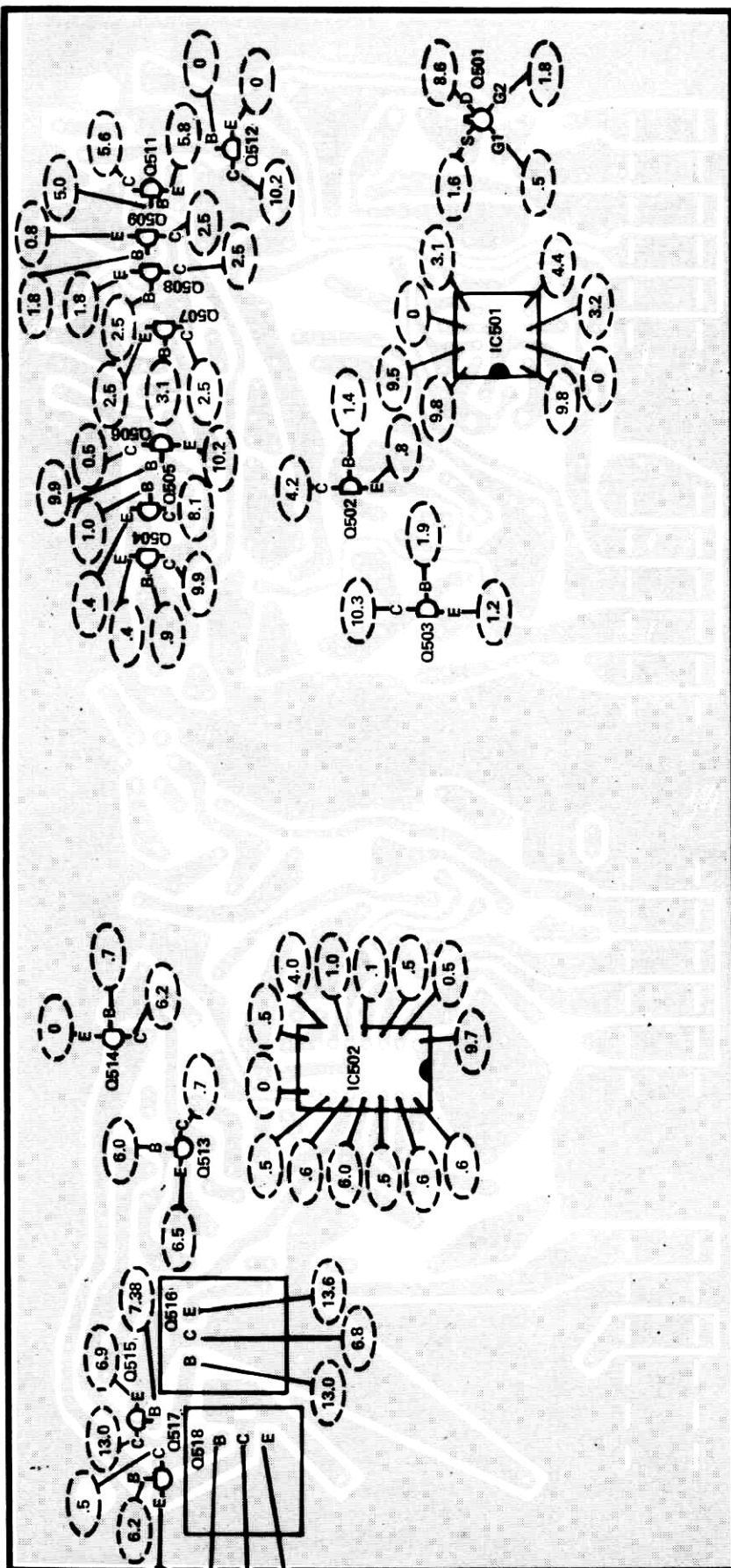

RECEIVER VOLTAGES ($\pm 20\%$)

NOTES:

1. POWER SUPPLY AND 4 Ω SPEAKER CONNECTED
2. ANTENNA NOT CONNECTED
3. BAND SWITCH IN 3.5 POSITION
4. RF GAIN MAXIMUM CLOCKWISE
5. AF GAIN MAXIMUM COUNTERCLOCKWISE
6. DC VOLTAGES MEASURED WITH 20 KILOHM INPUT VOM TO CHASSIS

() DC VOLTAGE WITH MODE SWITCH IN USB, LSB, OR CW POSITION

Receiver Front End Circuit Board

TROUBLESHOOTING CHART

SYMPTOM	POSSIBLE CAUSE
Preselector filter or filters cannot be aligned properly.	<ol style="list-style-type: none"> 1. Alignment cable soldered to wrong foil on counter board. 2. Filter coils interchanged between filters. 3. Switching diodes installed backwards, defective, or not properly biased. D701 – D718.
No HFO injection at pin 5 of T702.	<ol style="list-style-type: none"> 1. Check pin 6. If no signal, interconnecting cable may be improperly installed or defective. Check pin 2 on board D. 2. D719–D723 installed wrong.
No VFO injection at pin 5 of T703.	<ol style="list-style-type: none"> 1. Check pin 4. If no signal, check at VFO output on rear panel. 2. L728, C777, C778. 3. D724–D727 installed wrong.
No 8.65 MHz.	<ol style="list-style-type: none"> 1. Diodes installed wrong. 2. No HFO injection at T702 and T701. 3. Q702.
No 3.395 MHz output at pin 1.	<ol style="list-style-type: none"> 1. Diodes installed wrong. 2. D724–D727. 3. T703 and T704.
No +11 V at pin 13 in receiver mode.	<ol style="list-style-type: none"> 1. Q701.
No +11 V at pin 15 in transmit mode.	<ol style="list-style-type: none"> 1. Q701.

NOTE: Heath part numbers that correspond to the circuit component numbers in the Replacement Parts List start on Page 2-94 of this Manual.

CIRCUIT DESCRIPTION

The receiver front end establishes receiver selectivity and converts the incoming frequency to the 3.395 MHz IF. Broadband preselector filters, diode switched for each band, feed the antenna input to the first receiver mixer where the input and HFO signals are mixed to produce an 8.395-8.895 MHz IF signal. This is then mixed with the VFO input in the second mixer to obtain the 3.395 MHz IF.

In the 80 meter position, the Band switch places +11 VDC at R702 and R703, forward biasing diodes D701 and D702. Diodes D703, D704, D705, D706, D709, D710, D713, D714, D717, and D718 are back biased. This places the 80 meter filter, which consists of C701 through C706 (less C703) and L701 through L702, in the signal path and effectively removes all other filters from operation. Similarly, the filters for the 40 through 10 meter bands are

selected with the Band switch in the appropriate position. During transmit operation, +11 VDC is applied at R701 and R715, back biasing all preselector filters.

From the preselector filter, the input signal is fed through an 8.395 to 8.895 MHz band reject filter. The signal is then fed to diodes D719–D723, which form a balanced mixer. This mixer combines the HFO and the input signals to create an 8.395 to 8.895 MHz first IF signal at its output. This first IF signal is amplified by Q702 and filtered through an 8.395 to 8.895 MHz bandpass filter before it enters the second mixer. The first IF signal is then fed to diodes D724–D727, which form a second balanced mixer. This mixer combines the VFO and the first IF signal to create a 3.395 MHz second IF signal. The 3.395 MHz signal is coupled to the crystal filter circuit board.

RECEIVER FRONT END SCHEMATIC

CIRCUIT BOARD G

Refer to Page 2-46 for Schematic Notes.

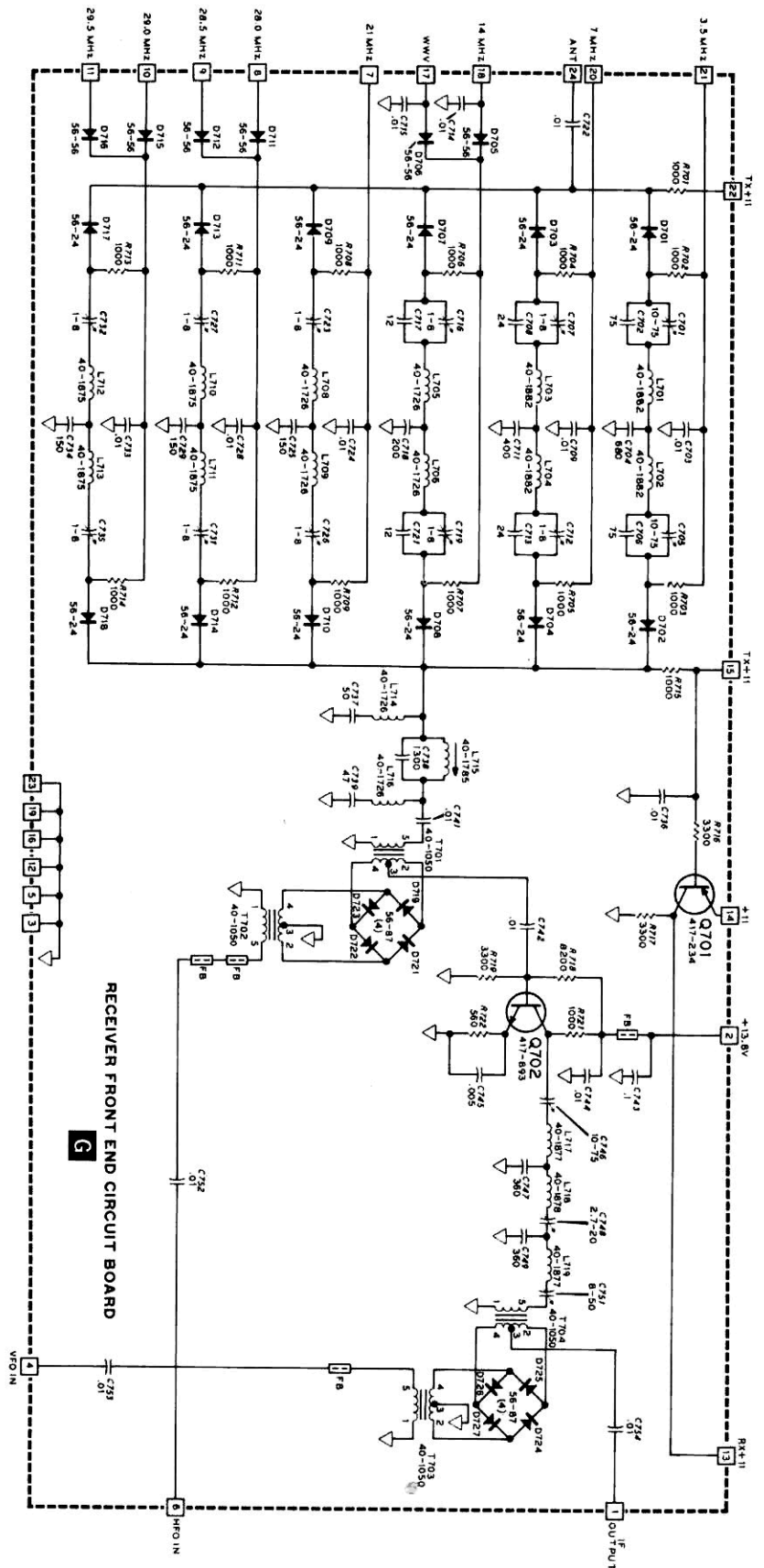

X-RAY VIEW

(Shown from component side)

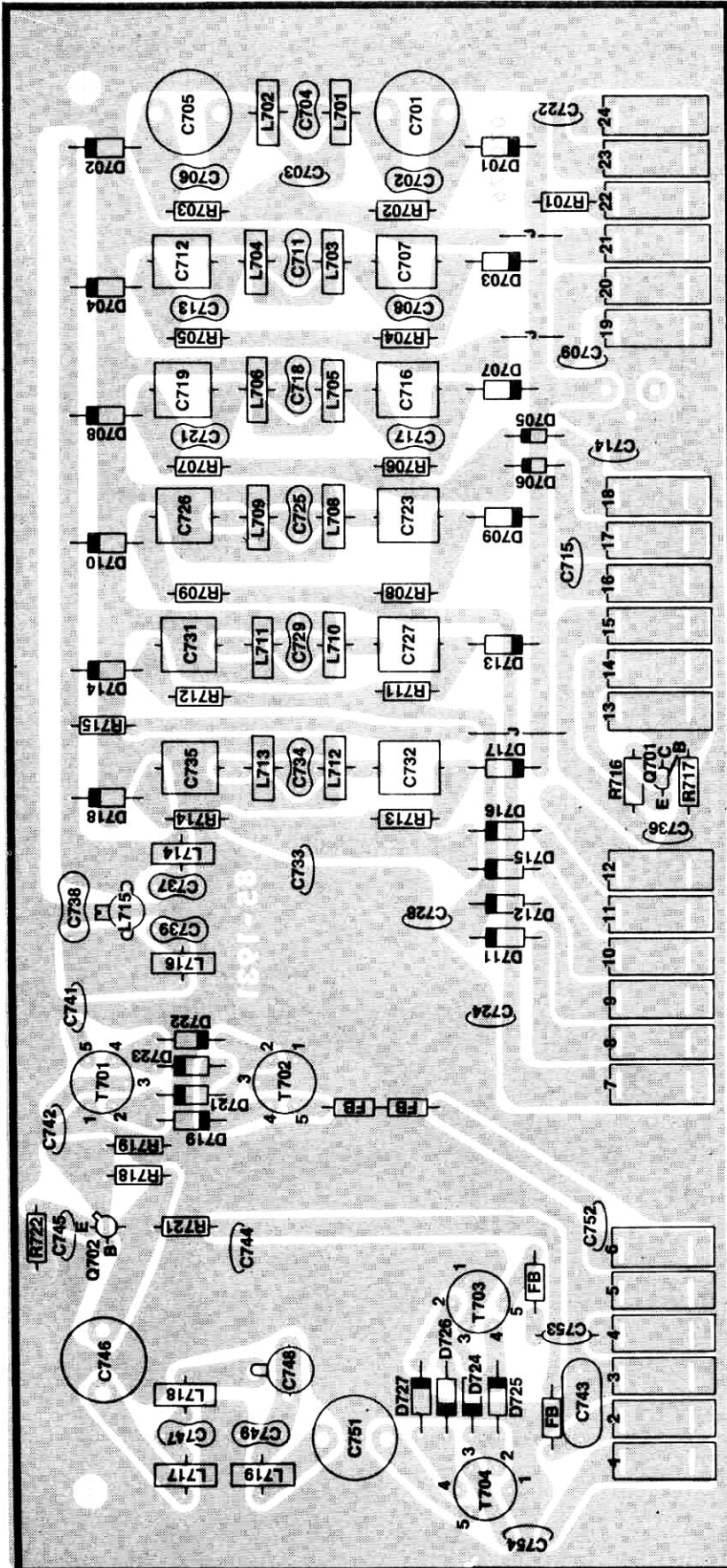

VOLTAGE CHART

(Shown from foil side)

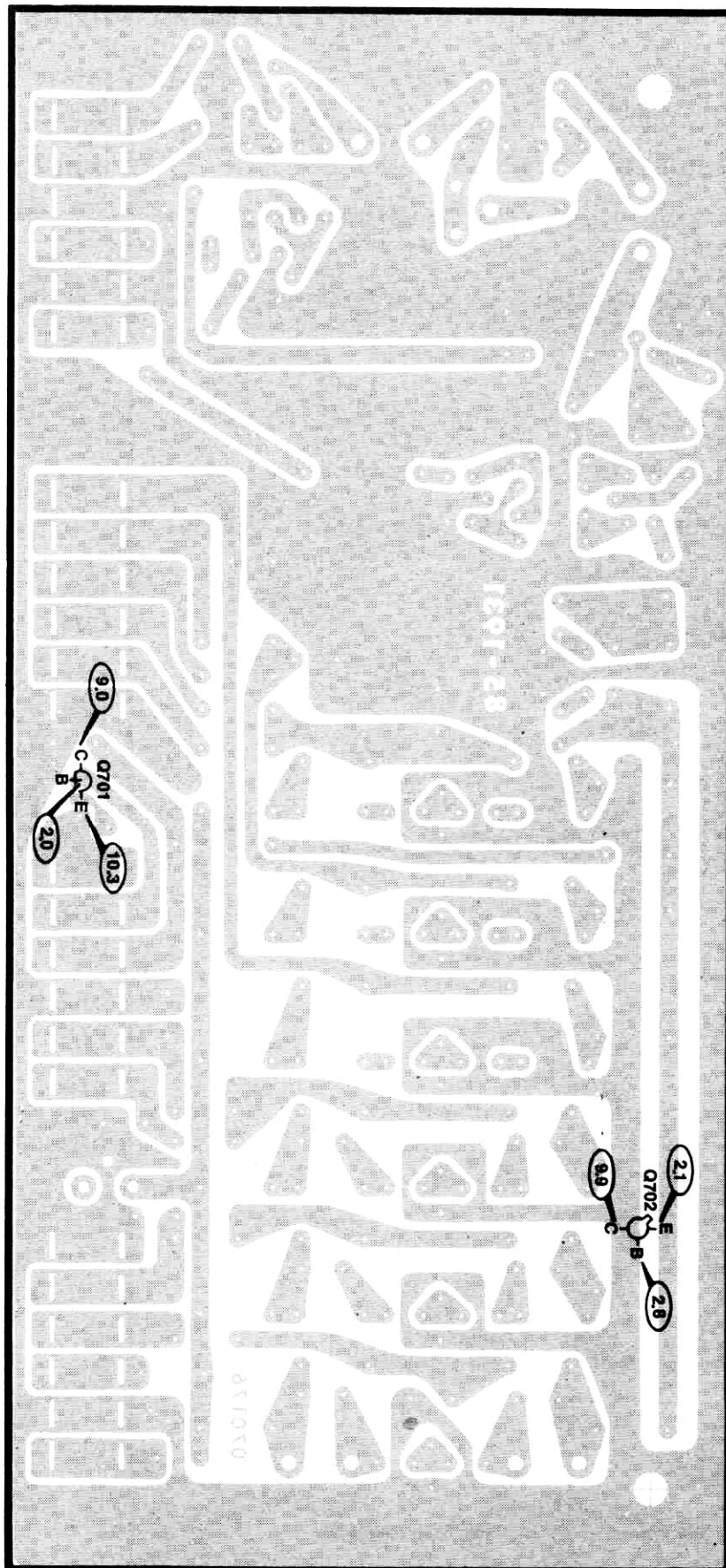

Voltage at Q702 taken with RF Gain fully clockwise.

RECEIVER VOLTAGES ($\pm 20\%$)

NOTES:

1. POWER SUPPLY AND 4 Ω SPEAKER CONNECTED
2. ANTENNA NOT CONNECTED
3. BAND SWITCH IN 3.5 POSITION
4. RF GAIN MAXIMUM CLOCKWISE
5. AF GAIN MAXIMUM COUNTERCLOCKWISE
6. DC VOLTAGES MEASURED WITH 20 KILOHM INPUT VOM TO CHASSIS

() DC VOLTAGE WITH MODE SWITCH IN USB, LSB, OR CW POSITION

REPLACEMENT PARTS LIST

CIRCUIT Component No.	DESCRIPTION	HEATH No.	CIRCUIT Component No.	DESCRIPTION	HEATH No.
RESISTORS, 1/4-Watt			INDUCTORS		
R722	560 Ω (green-blue-brown)	6-561-12	FB	Small ferrite bead	475-10
R701, R702, R703, R704, R705, R706, R707, R708, R709, R711 R712, R713, R714, R715, R721	1000 Ω (brown-black-red)	6-102-12	L715	.14 μ H coil	40-1785
R716, R717, R719 R718	3300 Ω (orange-orange-red)	6-332-12	L710, L711, L712, L713	4.5 μ H coil (red dot)	40-1875
	8200 Ω (gray-red-red)	6-822-12	L705, L706, L708, L709, L714, L716	7 μ H coil	40-1726
CAPACITORS			L717, L719	13.2 μ H coil (white and yellow dots)	40-1877
Mica			L701, L702, L703, L704	15.5 μ H coil (white dot)	40-1882
C717, C721	12 pF	20-130	L718	26.1 μ H coil (brown dot)	40-1878
C708, C713	24 pF	20-77	T701, T702, T703, T704	15 μ H transformer	40-1050
C739	47 pF	20-101	DIODES — TRANSISTORS		
C737	50 pF	20-97	D701, D702, D703, D704, D707, D708, D709, D710, D713, D714, D717, D718	1N458 diode	56-24
C702, C706	75 pF	20-147	D705, D706, D711, D712, D715, D716	1N4149 diode	56-56
C725, C729, C734	150 pF	20-149	D719, D721, D722, D723, D724, D725, D726, D727	FH1100 diode	56-87
C718	200 pF	20-165	Q701	2N3638A transistor	417-234
C747, C749	360 pF	20-131	Q702	2N5109 transistor	417-893
C711	400 pF	20-116	MISCELLANEOUS		
C704	680 pF	20-134		Board puller	207-80
C738	1300 pF	20-127		Circuit board connector	432-124
Disc				Circuit board	85-1931-1
C745	.005 μ F	21-46			
C703, C709, C714, C715, C722, C724, C728, C733, C736, C741, C742, C744, C752, C753, C754	.01 μ F	21-176			
Other					
C743	.1 μ F Mylar	27-47			
C707, C712, C716, C719, C723, C726, C727, C731, C732, C735	1-8 pF trimmer	31-68			
C748	2.7-20 pF trimmer	31-57			
C751	8-50 pF trimmer	31-36			
C701, C705, C746	10-75 pF trimmer	31-78			

RECEIVER FRONT END ALIGNMENT

NOTE: This circuit board was completely instrument aligned at the factory and should not require further adjustment unless a component is replaced.

The following alignment procedure should only be done if a component has been replaced and you feel adjustment is necessary. This procedure should give acceptable results in most cases. Some improvement may be noticed, especially on 10 meters, if the circuit board is instrument aligned.

- () Remove the phono plug from socket J101 on circuit board A. Then remove the circuit board from your Transceiver.
- () Locate your test cable (assembled on Page 2-30). Then refer to Figure 4-6 (Illustration Booklet, Page 12) and solder the free lead of the 18 pF capacitor to the foil designated TP on the circuit board A. Solder the cable shield wires to the ground foil in the area shown.
- () Carefully plug circuit board A back into its compartment. Look between the foil side of the circuit board and the shield to make sure the "hot" lead of the capacitor does not touch the shield.
- () Replace the phono plug in J101.
- () Remove circuit board G from the Transceiver.

Refer to Figure 4-7 (Illustration Booklet, Page 12) for the following steps.

- () Turn the slug in coil L715 until it is flush with the top of the coil form. Then turn the slug clockwise two complete turns.
- () Carefully remove and unsolder capacitor C741 from the circuit board. You will reinstall this capacitor later.
- () Push the end of the center conductor of the shielded cable coming from circuit board A into the hole at C741 that is closest to T701. Temporarily solder the wire to the foil. Bend the shield wires out of the way.

- () Install the extender board in position G.
- () Install circuit board G in the extender board.
- () Set the front panel controls as follows:

BAND Switch	7.0
RF GAIN	Fully clockwise
ALC button	Depressed
USB button	Depressed
AGC	Fast

IMPORTANT: ALWAYS turn the Transceiver OFF before you insert or remove a circuit board.

- () Depress the ON button.
- () Adjust the AF GAIN control for a comfortable listening level.
- () Tune the Transceiver to 7300 kHz. Then select the strongest signal within 5 kHz of this frequency.

When you perform any of the alignment steps in the remainder of this Manual, keep the S meter below a full scale indication by adjustment of the S-Meter Level Adjust control on circuit board F (see Figure 1-3, Illustration Booklet, Page 1). DO NOT use the RF GAIN control for this purpose.

- () Set the S-METER LEVEL ADJUST control (see Figure 1-3, Illustration Booklet, Page 1) for an S-meter reading of S9+20.
- () Adjust trimmer capacitors C746, C748, and C751 for maximum S-meter indication. Repeat this adjustment several times until there is no further improvement.
- () Tune the Transceiver to 7000 kHz and select the strongest signal within one-half of a tuning knob revolution.
- () Pull circuit board D up just enough to clear the connectors on the board's bottom edge.
- () Write down the S-meter reading.

- () Push circuit board D back down onto its connectors.
- () Tune the Transceiver to 7500 kHz and select the strongest signal within one-half of a tuning knob revolution.
- () Pull circuit board D up just enough to clear the connectors on the board's lower edge.
- () Write down the S-meter reading.
- () Repeat the above procedures at 7000 kHz and 7500 kHz and simultaneously adjust the trimmer capacitors C746 and C751 until the two S-meter readings are as close together as you can conveniently get them. The readings will probably never coincide exactly. Two or three repetitions of the adjustment should be adequate.
- () Unsolder and remove the shielded cable from circuit board G.
- () C741: Install the .01 μ F disc capacitor, removed from circuit board G, at C741. Solder the leads to the foil and cut off the excess lead lengths.

NOTE: If you will perform the "Preselector Bandpass Filter Alignment" immediately, disregard the following two steps and leave the extender board and circuit board G in position G.

- () Remove circuit board G from the extender board and the extender board from position G.
- () Reinstall circuit board G in position G.
- () Reinstall circuit board D.

NOTE: The shielded cable connected to circuit board A will be used in the following bandpass filter alignment steps.

PRESELECTOR BANDPASS FILTER ALIGNMENT

The object of this procedure is to adjust each bandpass filter for a uniform response across its frequency range. One filter is used for each of the 80, 40, 20, and 15 meter bands. Two filters are used for the 10 meter band, one for the 28.0 and 28.5 BAND switch positions, and one for the 29.0 and 29.5 positions. The alignment of a filter calls for a coarse adjustment to a center frequency, followed by equalizing adjustments at the band edges. Although the band edge responses will not be exactly equal, they will be reasonably close.

The following steps assume that the adjustment signal will be furnished by the counter (circuit board A) and that the S meter will be used as a signal level indicator. You may be able to improve the filter response to a small degree if you have a signal generator and an audio voltmeter available which you can substitute as a signal source and a level indicator. The signal generator can be connected directly to the ANT jack and the audio voltmeter across the SPKR terminals (to provide a load).

Figure 4-7 (Illustration Booklet, Page 12) identifies the trimmer capacitors to be adjusted for each BAND switch position.

- () Install a phono plug on the free end of the 24" shielded cable connected to circuit board A.
- () Insert the phono plug in the ANT jack on the rear panel (below the heat sink).
- () Check that the rear panel antenna switch is in the COM position.
- () Set the front panel controls as follows:

RF GAIN	Fully clockwise
ALC	Depressed
AGC	Fast
BAND	29.0
LEVEL	Fully counterclockwise
USB	Depressed
ON	Depressed

Buttons not mentioned should be released.

- () If it has not already been done, install the extender board and circuit board G in position G.
 - () Tune the Transceiver to the strongest signal in the vicinity of 29 400 kHz. NOTE: The counter provides many signals across the band, but the strongest signals will be heard at (or near) the 100 kHz points.
 - () Refer to Figure 4-7 and adjust the two trimmers for the 29.0 band to secure the greatest deflection of the S-meter needle. Repeat the adjustment two or three times until no greater deflection can be seen.
 - () Tune to the strongest signal near 29 100 kHz.
 - () Adjust the Low End trimmer for maximum S-meter deflection and write down the reading in the margin opposite this step.
 - () Turn the BAND switch to 29.5 and tune to 29 700 kHz.
 - () Adjust the High End trimmer for maximum S-meter deflection. Note the meter reading.
 - () Compare the two S-meter readings and adjust the trimmers according to the following examples:
- Examples:
1. If the meter reading at 29 700 kHz is lower than the 29 100 kHz reading, adjust the Low End trimmer to increase the meter reading.
 2. If the meter reading at 29 100 kHz is lower than the 29 700 kHz reading, turn the BAND switch to 29.0 and tune the Transceiver to 29 100 kHz. Then adjust the High End trimmer to increase the meter reading.
- () Turn the BAND switch to 28.5 and tune the Transceiver to the strongest signal near 28 900 kHz.
 - () Adjust the High End trimmer for the greatest S-meter deflection and note the meter reading.
 - () Tune the Transceiver to the frequency having the lower meter reading, if necessary. If the 28 900 kHz frequency has the lower meter reading, adjust the Low End trimmer to increase the reading. If the 28 100 kHz frequency had the lower reading, turn the BAND switch to 28.0, tune to 28 100 kHz, and adjust the High End trimmer to increase the meter reading.
 - () Repeat the adjustments two or three times for the most uniform response across the band.
 - () Follow the same procedure and adjust the bandpass filters for the 21.0, 14.0, 7.0, and 3.5 bands. The trimmers for each band are shown in Figure 4-7. Refer to Figure 4-8 for the three frequencies to use for the adjustments of each filter.

BAND	FREQUENCIES		
	MID-BAND (ADJ. BOTH TRIMMERS)	LOW END	HIGH END
29.0 29.5	29 400	29 100	29 700
28.0 28.5	28 500	28 100	28 900
21.0	21 100	21 100	21 400
14.0	14 200	14 100	14 400
7.0	7 100	—	—
3.5	3 800	3 600	3 900

Figure 4-8

- () Repeat the preceding adjustments two or three times to secure the most uniform response.
- () Turn the BAND switch to 28.0 and tune the Transceiver for the strongest signal near 28 400 kHz.
- () Tune both trimmers for this band for maximum S-meter deflection. Repeat the adjustments for the highest S-meter reading.
- () Tune the Transceiver for the strongest signal near 28 100 kHz.
- () Adjust the Low End trimmer for maximum S-meter deflection and note the meter reading.
- () Tune the Transceiver to 3800 kHz. Then select the strongest signal within 5 kHz of this frequency.
- () Set the S-METER LEVEL ADJUST control (see Figure 1-3, Illustration Booklet, Page 1) for an S-meter reading of S9+50.
- () Turn the Transceiver OFF.
- () Remove the phono plug from the ANT socket on the rear panel and unsolder and remove the shielded cable and the 18 pF capacitor from the foil side of circuit board A.
- () Remove the extender board and reinstall circuit board G in position G.

Power Amplifier Circuit Board

TROUBLESHOOTING CHART

SYMPTOM	POSSIBLE CAUSE
No RF output.	<ol style="list-style-type: none">1. Transistors. See "P.A. Transistor Check" on Page 2-101.2. Inductors (coils) connected wrong.3. No 13.8V at pins 5 and 6.4. No .7V at pin 1.5. Pins 2 and 4 not grounded.

NOTE: Heath part numbers that correspond to the circuit component numbers will be found in the Parts List starting on Page 1-119 of the Assembly Manual.

CIRCUIT DESCRIPTION

The function of this circuit is to amplify the driver output to the 100-watt level. Basically, it consists of two push-pull pairs combined into one amplifier.

assured by the 100 ohm resistors across the input and output circuits. Hybrid combiners are used to split the drive power between pairs and to combine the outputs of the two amplifier pairs.

Q951 and Q952 comprise one push-pull pair, and Q953 and Q954 the other. Bias is applied to the input transformer center taps, and is derived from a heat-sink mounted diode. As the diode is mounted on the same heat sink as the power amplifier, the bias voltage tracks the power amplifier temperature, preventing thermal runaway. Power balance is

The power amplifier, like the driver, is broadband, with essentially flat response from 3 to 30 MHz. Harmonics are attenuated by the low pass filter (board K), and additional selectivity is not required. It is this characteristic that makes the "no-tune-up" feature possible.

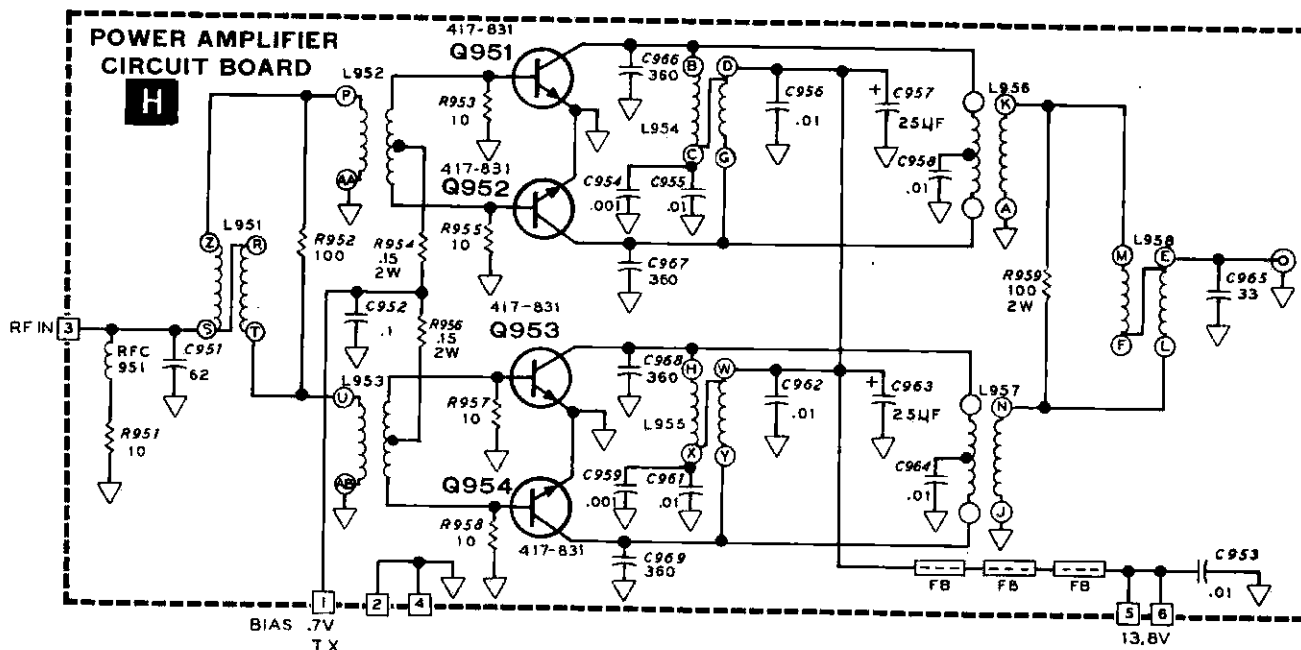

POWER AMPLIFIER SCHEMATIC

CIRCUIT BOARD H

Refer to Page 2-46 for Schematic Notes.

X-RAY VIEW

(Shown from component side)

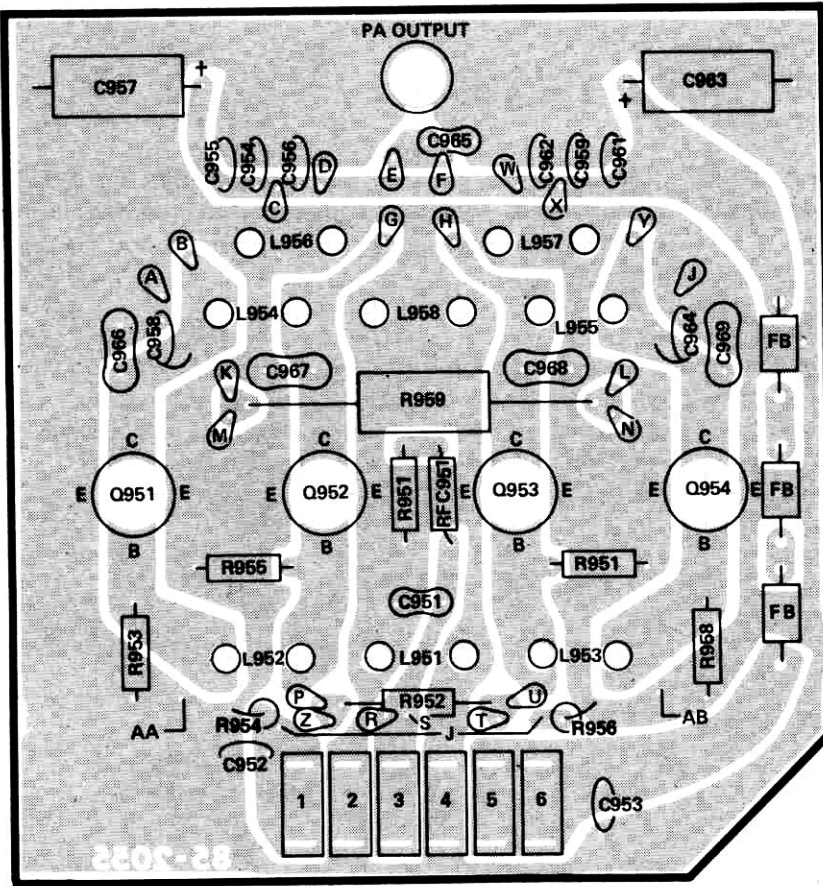

VOLTAGE CHART

(Shown from component side)

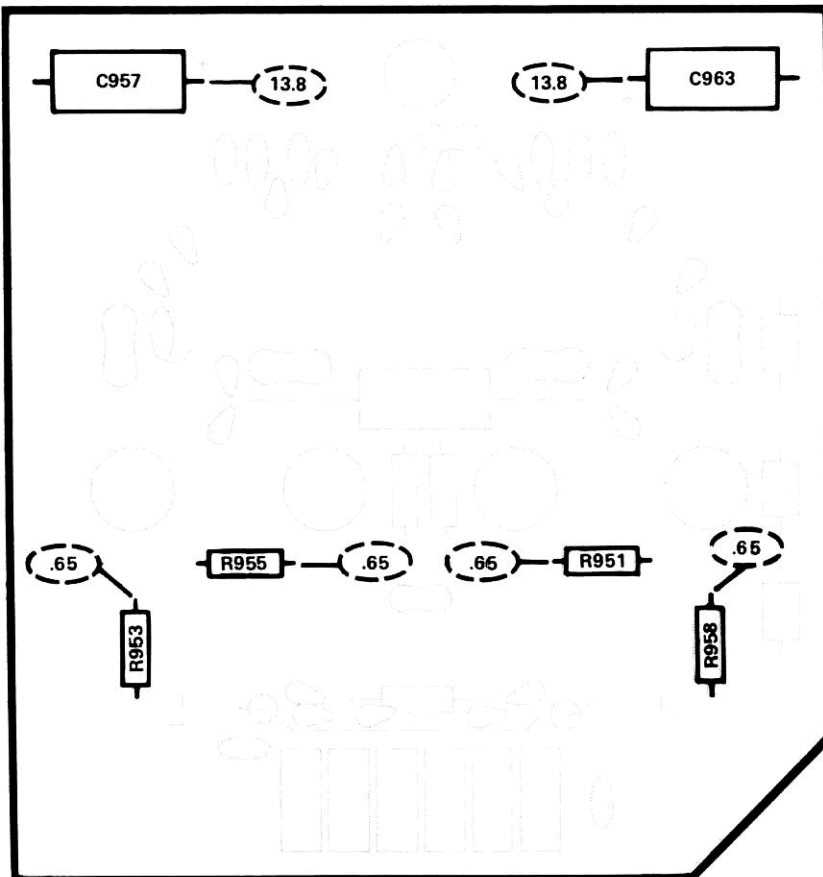

RECEIVER VOLTAGES ($\pm 20\%$)

NOTES:

1. POWER SUPPLY AND 4Ω SPEAKER CONNECTED
2. ANTENNA NOT CONNECTED
3. BAND SWITCH IN 3.5 POSITION
4. RF GAIN MAXIMUM CLOCKWISE
5. AF GAIN MAXIMUM COUNTERCLOCKWISE
6. DC VOLTAGES MEASURED WITH 20 KILOHM INPUT VOM TO CHASSIS

(---) DC VOLTAGE WITH MODE SWITCH IN USB, LSB, OR CW POSITION

P.A. TRANSISTOR CHECK

Use the following check to determine whether the P.A. transistors are defective:

1. Connect an antenna or dummy load to the ANT jack on the rear panel.
2. Set your voltmeter on its lowest scale (1.5V or higher) and connect its common lead to the chassis.
3. Depress the SSB, ON and HI buttons. The TUNE button must be released.
4. Key the Transceiver by using the PTT microphone switch.
5. Connect the input probe of your voltmeter first to the foil of L952 and then to the foil of L953. At each foil you should obtain the following "normal" reading on the TX line. If you obtain a "bad" reading, see paragraph 8 following.

	<u>NORMAL</u>	<u>BAD</u>
TX (HI PWR)	0.65V	1.2V
RX	OV	1.2V

6. Release the HI button and the PTT switch.
7. Repeat the checks in paragraph 5. You should obtain the readings on the RX line above.

8. If you obtain a "bad" reading in either the TX or RX checks, all four final transistors should be replaced. These are sold by Heath only as a matched set of four transistors. Refer to "Power Amplifier Warranty" on Page 2-45 for the special one-year warranty.

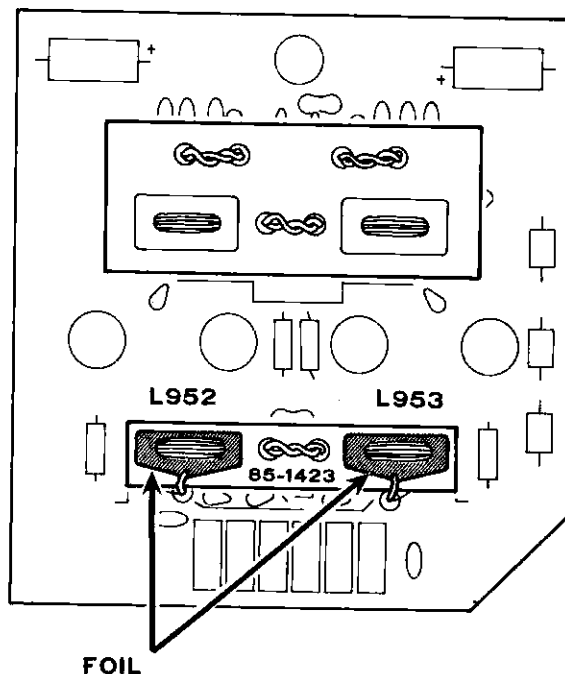

Figure 4-2 (Repeat)

Driver Circuit Board

TROUBLESHOOTING CHART

SYMPTOM	POSSIBLE CAUSE
Low output.	<ol style="list-style-type: none"> 13.8V missing. Q901, Q902. L901, L902. D903, D904.
ALC inoperative.	<ol style="list-style-type: none"> Low input from TX IF/predriver (board C). D905, D906. Poor load impedance.

NOTE: Heath part numbers that correspond to the circuit component numbers will be found in the Parts List starting on Page 1-73 of the Assembly Manual.

SCHEMATIC CIRCUIT BOARD J

Refer to Page 2-46 for Schematic Notes.

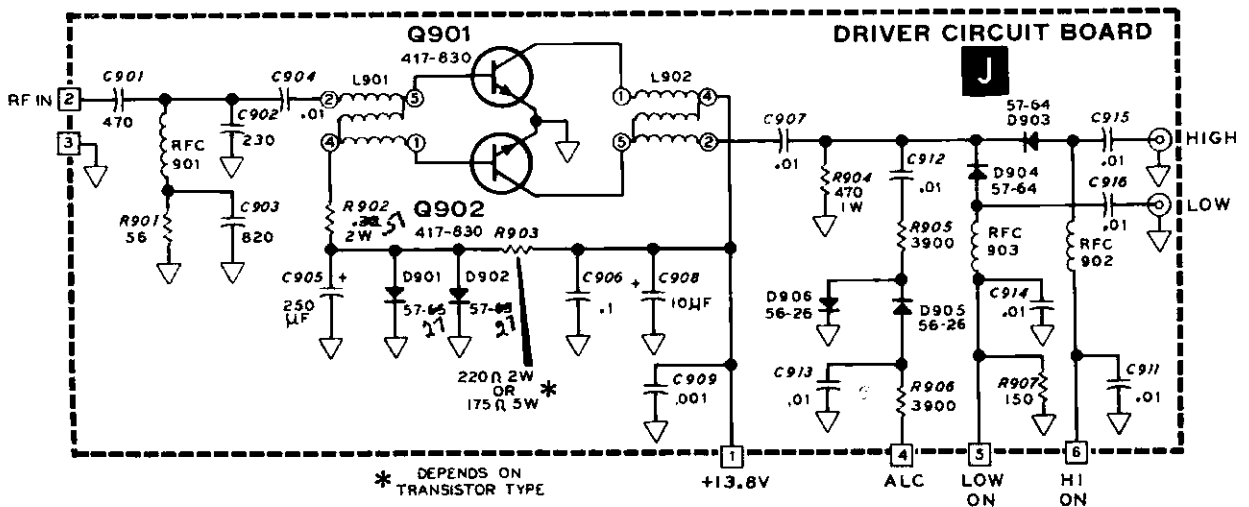

X-RAY VIEW

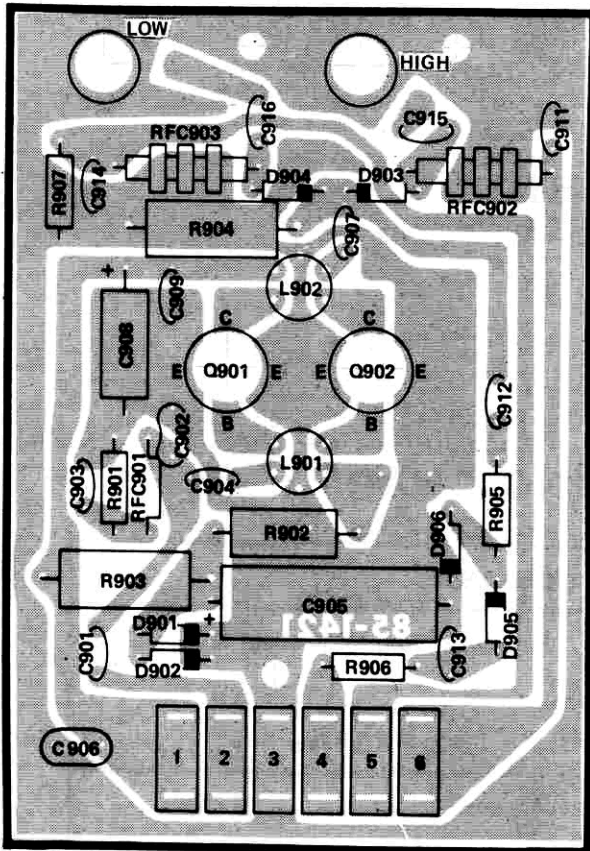

(Shown from component side)

VOLTAGE CHART

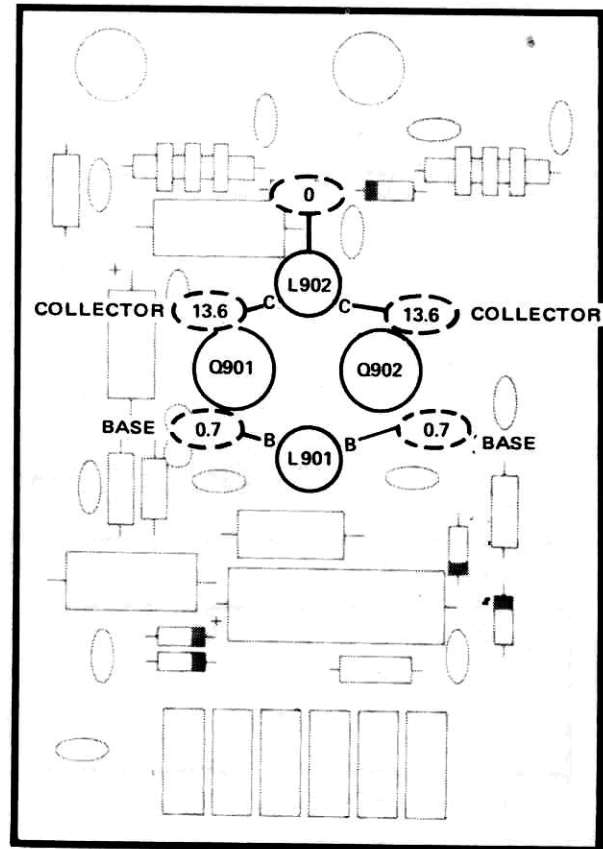

(Shown from component side)

RECEIVER VOLTAGES (±20%)

NOTES:

1. POWER SUPPLY AND 4Ω SPEAKER CONNECTED
2. ANTENNA NOT CONNECTED
3. BAND SWITCH IN 3.5 POSITION
4. RF GAIN MAXIMUM CLOCKWISE
5. AF GAIN MAXIMUM COUNTERCLOCKWISE
6. DC VOLTAGES MEASURED WITH 20 KILOHM INPUT VOM TO CHASSIS

() DC VOLTAGE WITH MODE SWITCH IN USB, LSB, OR CW POSITION

CIRCUIT DESCRIPTION

The function of this circuit is to amplify the predriver output to a level sufficient to drive the power amplifier.

Transistors Q901 and Q902 are used in a push-pull, class AB linear configuration. D901 and D902 are used to provide proper operating bias. Gain flatness across the range is provided by the network at the input of the driver.

Diodes D903 and D904 route the driver output to the low-pass filter (low power mode) or to the power amplifier (high power mode). These diodes are controlled by the relay switching line in conjunction with the HI switch.

Diodes D905 and D906 sample and rectify a portion of the driver output, producing a voltage used for ALC in the low power mode.

ALC/Output Circuit Board

TROUBLESHOOTING CHART

SYMPTOM	POSSIBLE CAUSE
High signal loss, all bands.	<ol style="list-style-type: none">1. Band switch rotor positioned wrong.2. Shorted coaxial cable.3. 10/15 meter filter components.
High signal loss, one band.	Filter components for that band.
Low output in high power.	<ol style="list-style-type: none">1. PA circuit board.2. High line VSWR.3. Leads of L813 reversed or L813 defective.

CIRCUIT DESCRIPTION

The function of the low pass ALC/Output Circuit is to attenuate the harmonics present in the driver and power amplifier outputs to acceptable levels, and to provide ALC control voltage in the high power mode.

Four low-pass filters are used, one each for 80, 40, 20, and 15/10 meters. The 15 and 10 meter bands use one filter, as the second harmonic of 15 meters falls well above the 10 meter band. These filters are selected by a circuit board — mounted rotary switch, ganged with the main Band switch. This is the only bandswitching in the Transceiver which is not solid-state, due to the power levels involved.

From the filters, the output signal is routed through the directional coupler. This coupler provides outputs for forward and reflected power. These outputs are combined to form an ALC voltage, used in the high power mode. In this manner, higher ALC voltages are generated when the antenna line VSWR is high, reducing the transmitter output power to a level which will not damage the power amplifier.

Q801 and Q802 form a switch which changes the ALC time constant between Slow (SSB) and Fast (CW and TUNE). D803 is used to provide voltage for the relative power metering function.

ALC/OUTPUT SCHEMATIC

CIRCUIT BOARD K

Refer to Page 2-46 for Schematic Notes.

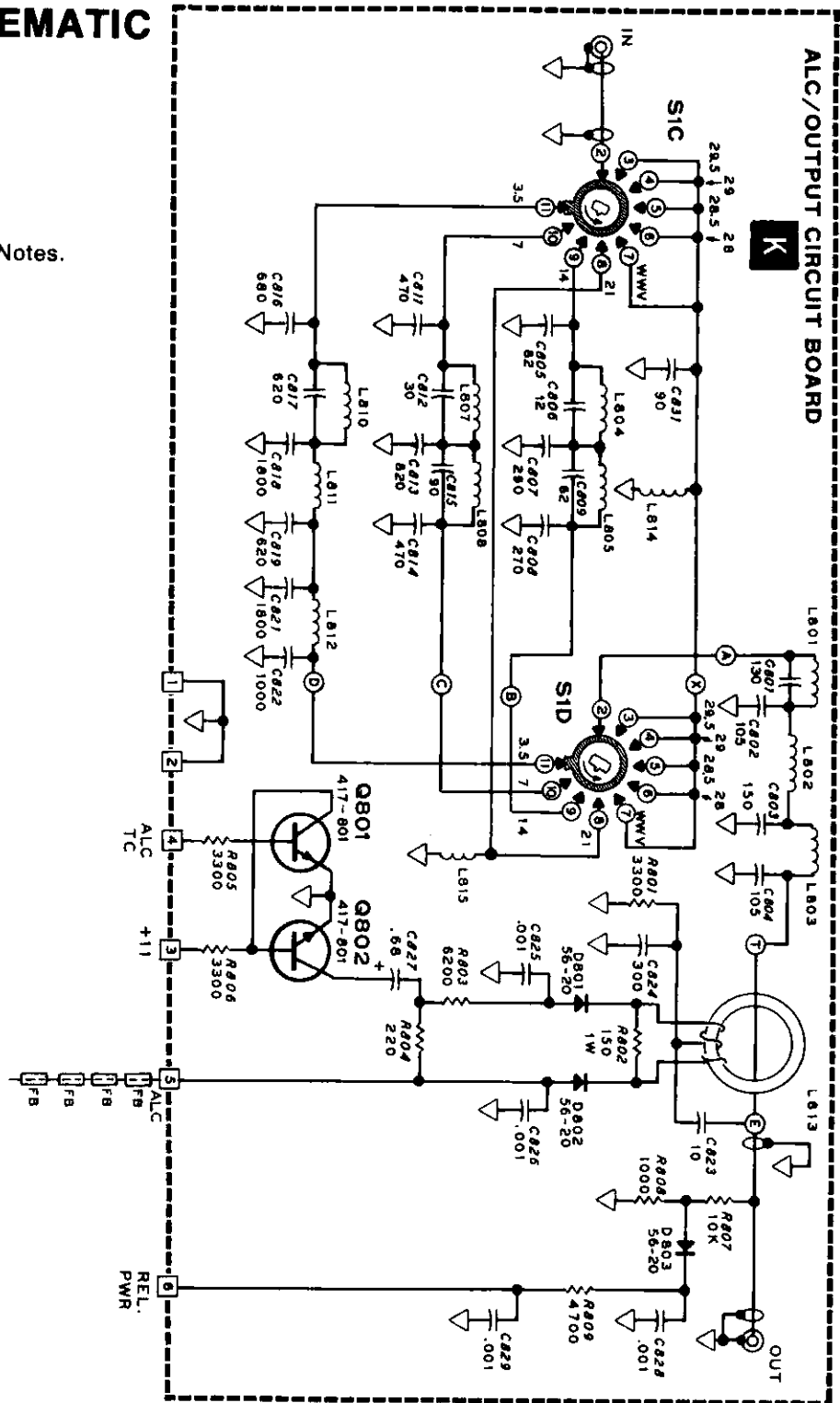

NOTE: Heath part numbers that correspond to the circuit component numbers will be found in the Parts List starting on Page 1-83 of the Assembly Manual.

X-RAY VIEW

(Shown from component side)

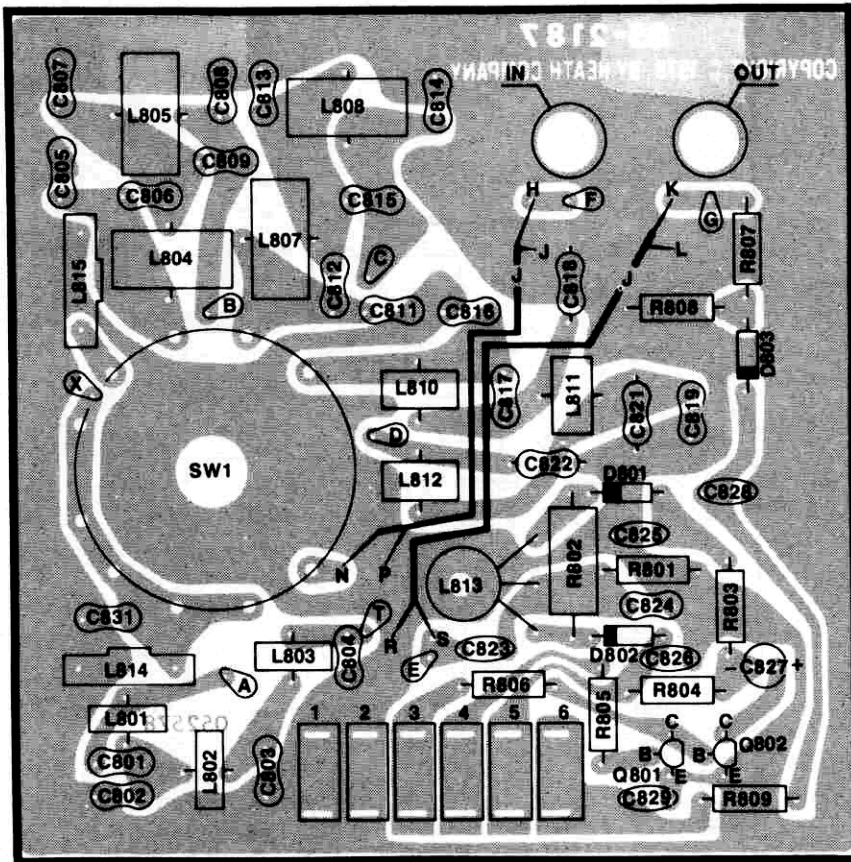

VOLTAGE CHART

(Shown from component side)

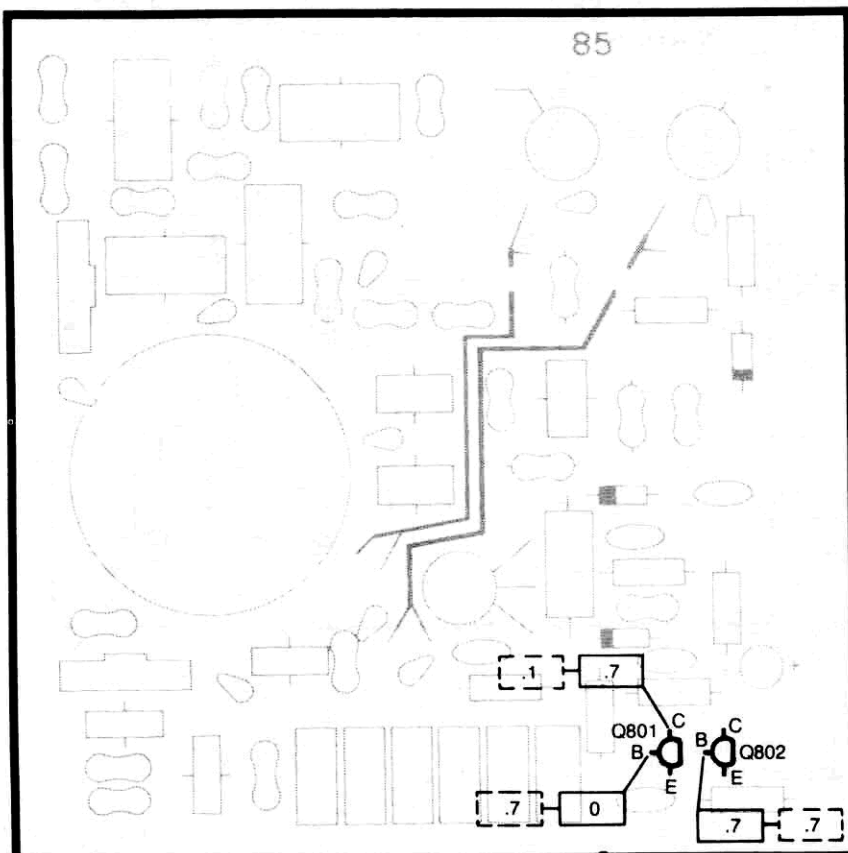

TRANSMITTER VOLTAGES ($\pm 20\%$)

NOTES:

1. BANDSWITCH IN 3.5 POSITION
2. MODE SWITCH IN TUNE POSITION
3. METER SWITCH IN PWR POSITION
4. MIC/CW-LEVEL FULLY COUNTERCLOCKWISE

 DC VOLTAGE WITH MODE SWITCH IN USB OR LSB POSITION

 DC VOLTAGE WITH MODE SWITCH IN CW POSITION

SPECIFICATIONS

GENERAL

Frequency Readout	6-digit electronic display.
Active Devices	All solid-state.
Frequency Coverage (Megahertz)	3.5 to 4.0, 7.0 to 7.3, 14.0 to 14.5, 21.0 to 21.5, 28.0 to 29.7. 15.0 to 15.3 (receive only).
Frequency Stability	Less than 100 Hz/30-min. drift after 30-min. warmup; less than 100 Hz drift for \pm change in primary voltage.
Modes of Operation	Selectable upper or lower sideband (suppressed carrier) and CW.
Readout Accuracy	Within ± 200 Hz (± 1 count).
Audio Frequency Response	350 to 2450 Hz ± 75 Hz (6 dB bandwidth).
Tuning Backlash	100 Hz.
Phone Patch Impedance	4 ohm output to speaker; high impedance output to transmitter.
DC Requirements.	12.6 to 16 VDC at 20 amperes.* Typical current draw: Receive: 2 amps. Transmit, low power: 3 amps. Transmit, high power: 20 amps.

TRANSMITTER

RF Power Output	<u>High Power</u> (50 Ω nonreactive load). SSB: 100 watts PEP ± 1 dB. CW: 100 watts ± 1 dB; <u>Low Power</u> SSB: 1 watt PEP (minimum). CW: 1 watt (minimum).
---------------------------	---



Output Impedance	50 ohms, less than 2:1 SWR.
Carrier Suppression	50 dB down from 100 watt single-tone output at 1000 Hz reference.
Unwanted Sideband Suppression	55 dB down from 100 watt single-tone output at 1000 Hz reference.
Harmonic Radiation	40 dB below 100 watt output.
Spurious Radiation	-40 dB within ± 4 MHz of carrier. -60 dB greater than ± 4 MHz from carrier, except, on the 10 meter band, -50 dB.
Third Order Distortion	30 dB down from two-tone output, reference at 100 watts PEP.
Transmit/Receive Operation	SSB: PTT or Vox. CW: Keyed-tone Vox or Manual. NOTE: In the low power mode all transmit-receive switching is solid state.
CW Sidetone	Internally switched to speaker or headphones in CW mode. Approximately 700 Hz tone.
Microphone Input	High impedance with a rating of -45 to -55 dB; approximately 25 k Ω to match Heath desk-type microphone.

RECEIVER

Sensitivity	Less than .5 microvolt for 10 dB signal plus-noise-to-noise ratio for SSB operation.
Selectivity	2.1 kHz minimum at 6 dB down, 5 kHz maximum at 60 dB down. (2:1 nominal shape factor.)
CW Selectivity (with accessory CW filter)	400 Hz at 6 dB down, 2 kHz at 60 dB down.
Overall Gain	Less than 1 microvolt for 0.5 watt audio output.
Audio Output	2.5 watts into 4 ohms, 1.25 watts into 8 ohms, at less than 10% THD. Low impedance headphones (4-8 ohm).

AGC	Less than 1 millisecond attack time; switch selectable 100 millisecond and 1 second release, and OFF.
Intermodulation Distortion	-60 dB.
Image Rejection	-60 dB.
IF Rejection	-60 dB for 8.395 to 8.895 MHz. -55 dB for 3.395 MHz.
Internally Generated Spurious Signals	Below 2 microvolt equivalent antenna input, except at 3.65, 3.74, 14.24, 21.2, 28.46, 28.9, and 29.33 MHz.
Cabinet Dimensions (Less knobs, feet, sockets, rails)	5-3/4" high × 14-15/32" wide × 13-7/8" deep. (14.6 × 36.8 × 35.2 cm.)
Net Weight	20 lbs. (9 kg)

The Heath Company reserves the right to discontinue products and to change specifications at any time without incurring any obligation to incorporate new features in products previously sold.



THEORY OF OPERATION

While reading this section, refer to the large Schematic fold-in.

RECEIVER

Refer to the "Receiver Block Diagram," (Illustration Booklet, Page 9).

The incoming signals pass through the Filter/ALC circuit board to the Receiver Front End board if the same antenna is used for receiving and transmitting. If the separate receiving antenna connection is used, the incoming signals are applied directly to the Receiver Front End circuit board.

The incoming signal next passes through the appropriate bandpass filter on the Receiver Front End circuit board, and is then mixed with the signals from the VFO and the HFO to form the 3395 kHz IF signal.

The IF signal is connected to the Carrier Generator/Crystal Filter circuit board which contains a selective crystal filter for SSB, and generates the USB, LSB, and CW BFO signals. Solid-state switching is used for mode selection and also to select the proper filter if the optional CW crystal filter is installed.

The 3395 kHz IF signal is fed to the Receiver IF/Audio circuit board where it is amplified, detected, and the audio signal again amplified. The RF Gain control varies the IF gain. AGC voltage is detected and amplified on this circuit board. The circuit provides fast, slow, or off AGC action. The S-meter driver operates in conjunction with the AGC voltage. Audio inputs, outputs and controls are connected to this circuit board.

TRANSMITTER

Refer to the "Transmitter Block Diagram," (Illustration Booklet, Page 10).

The Transmitter Audio/Regulator circuit board accepts the microphone, key, and phone patch inputs, which it processes and controls. It regulates the 5 and 11 volt DC voltages used throughout the Transceiver. The functions located on this circuit board are the audio preamplifiers, the VOX and PTT circuits, the keying circuits, the CW sidetone generator, the relay driver, the SSB/CW control, and the aforementioned voltage regulators.

The Carrier Generator/Crystal Filter circuit board contains the balanced modulator, which mixes the transmitter audio and the appropriate carrier (BFO). The carrier is then balanced out, leaving a double sideband signal, one sideband of which is removed by the crystal filter.

The 3395 kHz IF signal is amplified on the Transmitter IF/Predriver circuit board. The IF signal and the premix signal are combined in the balanced mixer, and are then passed through a bandpass filter, after which they are again amplified. Keying is accomplished at this point by turning these amplifiers on and off. The amplifiers are followed by a second group of bandpass filters, which are followed by the Driver circuit board.

The HFO signals for the various bands are generated by crystal oscillators on the HFO/Premix circuit board. These

signals are mixed with the VFO output to form a premix signal, which is then filtered by a group of bandpass filters.

The VFO operates over a range of 500 kHz. Its output is fed to the HFO/Premix board, where it is processed as a component of the premix signal.

The Driver circuit amplifies the signal to the level required to drive the Power Amplifier. However, the Driver output can also be switched to bypass the Power Amplifier and furnish a QRP signal direct to the ALC/output board and the antenna. Part of the output is rectified and used for ALC voltage in the low power mode.

The Power Amplifier consists essentially of two push-pull amplifiers operated in parallel. Their bias voltage is furnished by a diode mounted in the heat sink, so the bias voltage tracks with the heat sink temperature to prevent thermal runaway. The circuit is broad-banded and no tuning of the power amplifier output circuit is required.

The ALC/output circuit board contains low-pass filters to attenuate harmonics which must be suppressed to prevent interference to other services. Solid-state switching is used to change the ALC time constant for SSB and CW. Part of the power output is rectified and connected to the panel meter for the Relative Power indication.

DISPLAY

Refer to the Display Block Diagram (Illustration Booklet, Page 12).

The frequency display is processed on two circuit boards — the counter board and the display board.

On the counter board, a stable crystal oscillator acts as the time base, calibrated against station WWV. A divider string and associated gates provide the gate, transfer, and reset pulses.

If the BFO frequency is subtracted from the premix frequency, the result is the signal frequency. Therefore, the counter is automatically preset to start counting below an arbitrary 0 by the amount of the BFO frequency. In this

way, the entire premix frequency is counted but only the signal frequency is displayed.

When the transfer pulse occurs, the count is transferred from five counters to memory latches, which retain the count at their outputs for the duration of the counting cycle.

The Display circuit board contains segment drivers, five of which receive and process the count from the memory latches. The drivers turn on the appropriate elements in the display tubes.

The first (left-hand) digit of the display is controlled by the band switch so the digit will be unlighted or show a "1" or a "2" as appropriate for the Band switch position.

CHASSIS PHOTOGRAPHS

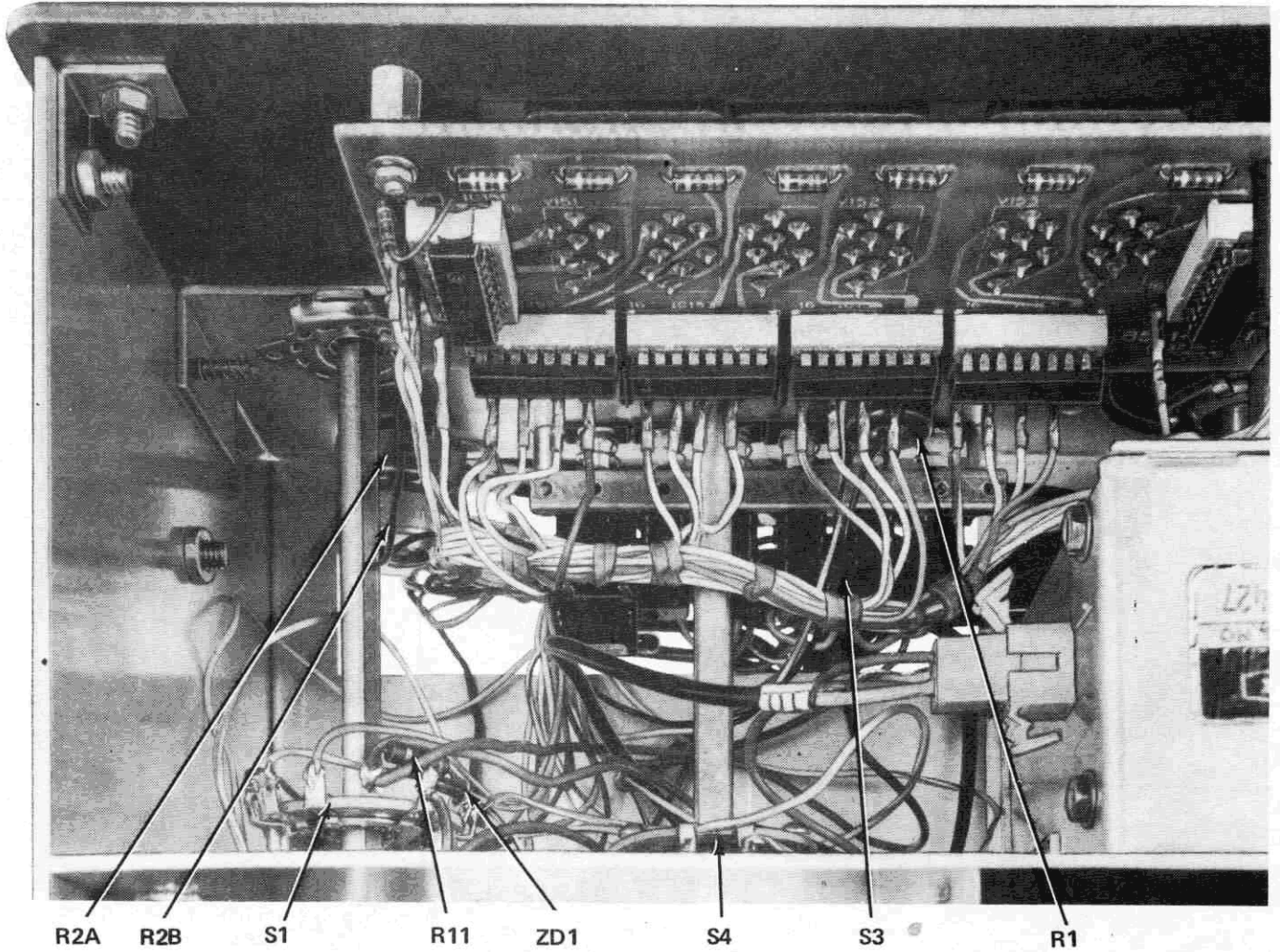

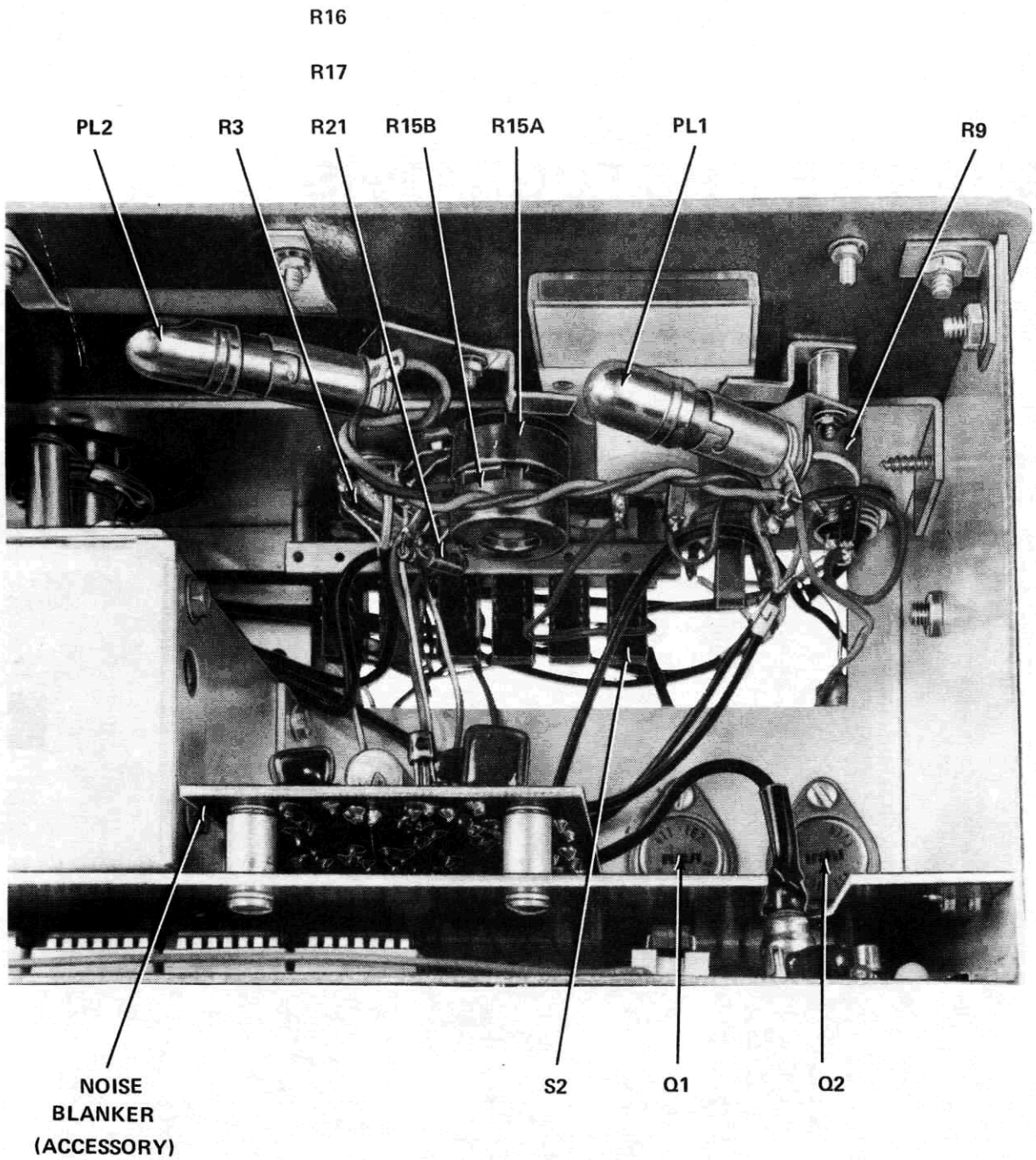

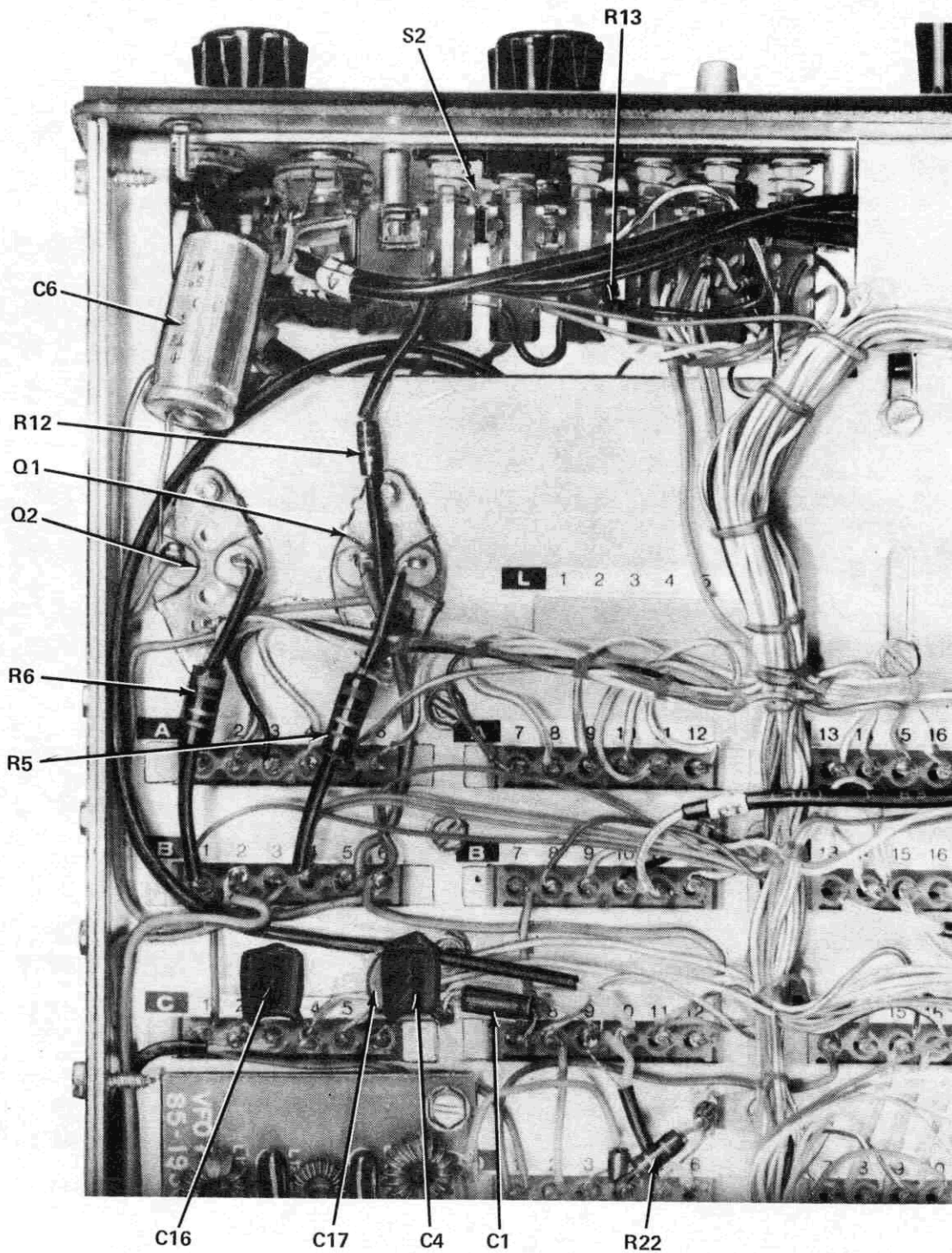

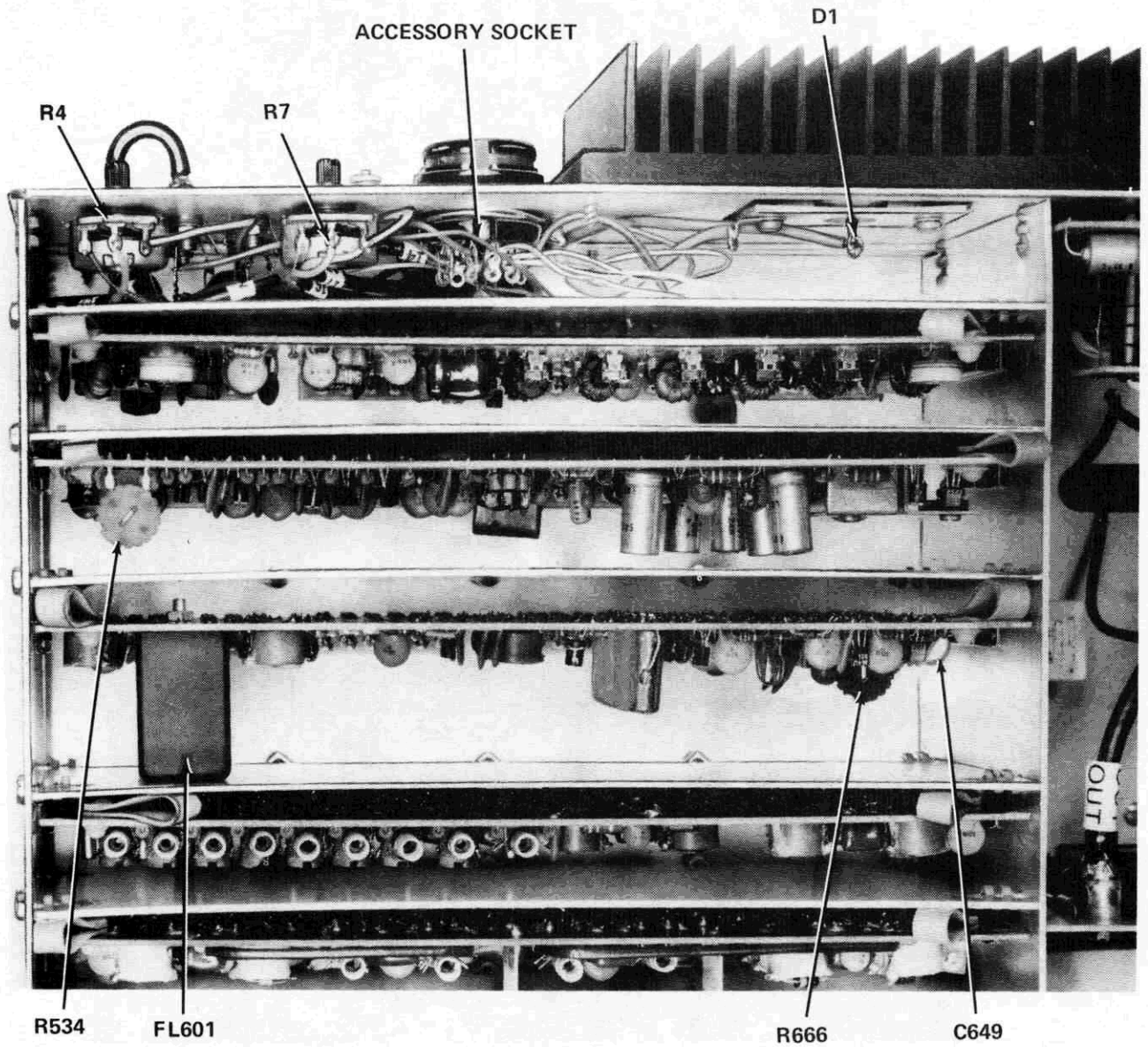

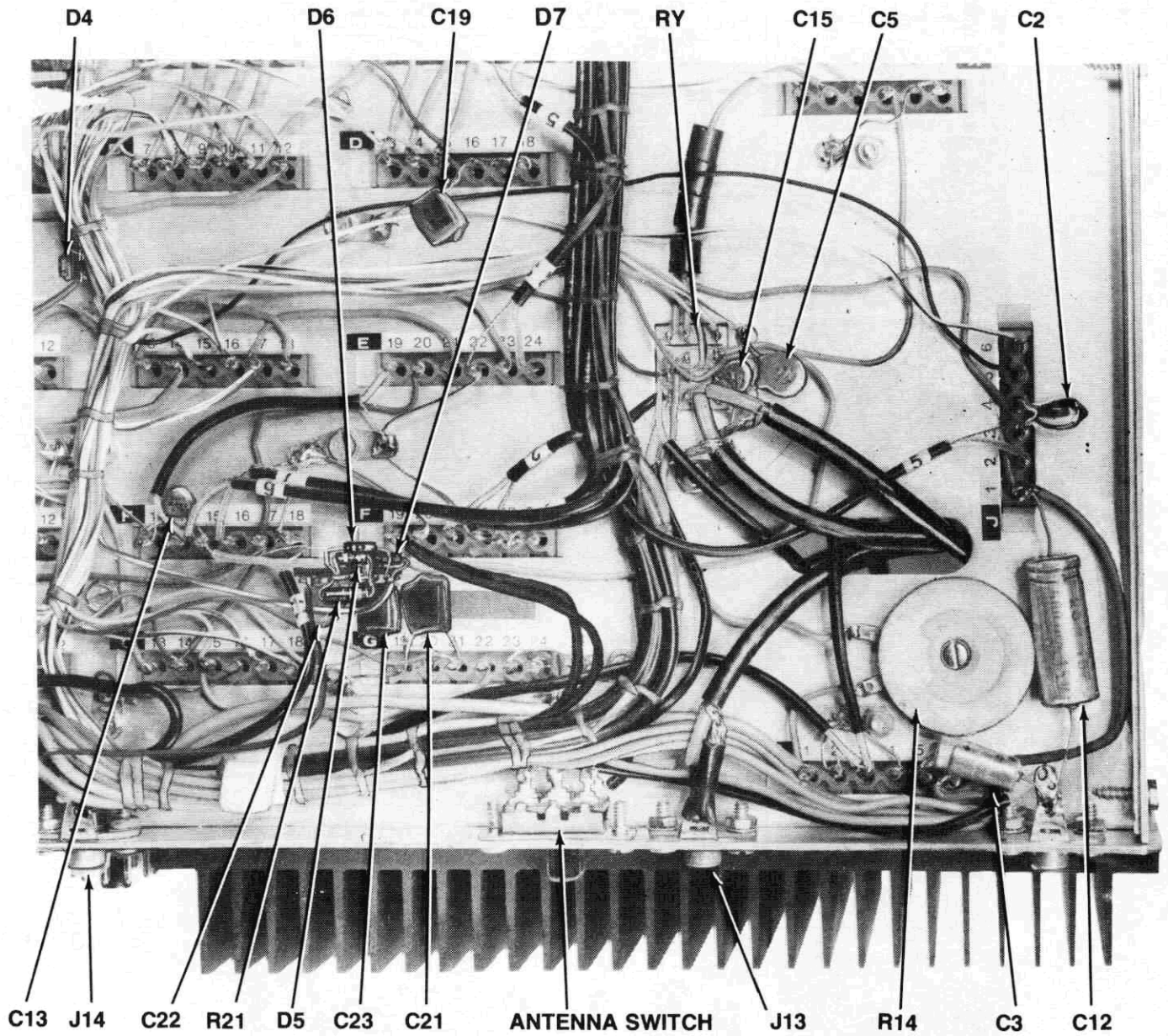

D1

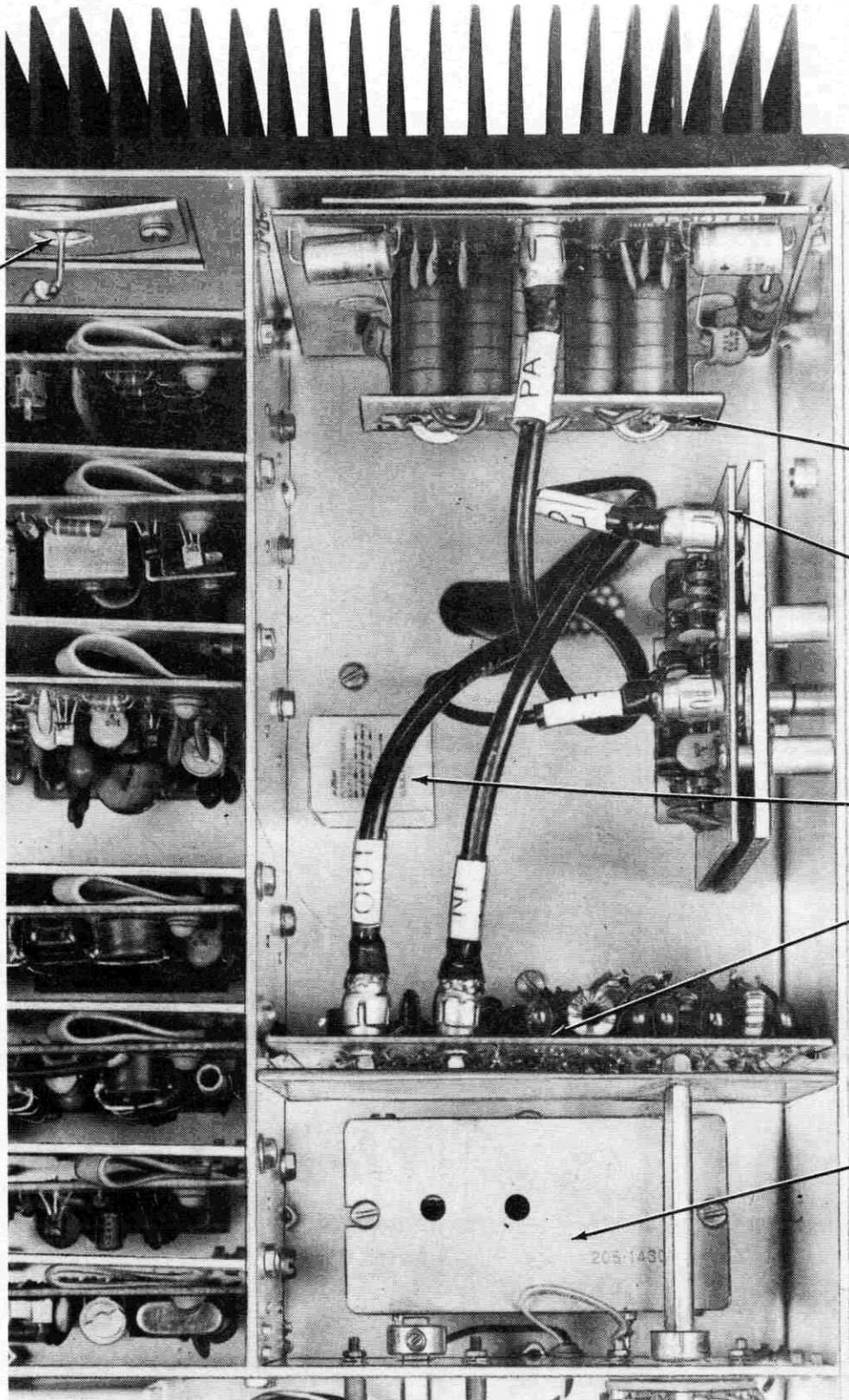

POWER
AMP

DRIVER

RY

ALC/OUTPUT

CONVERTER

205-1431

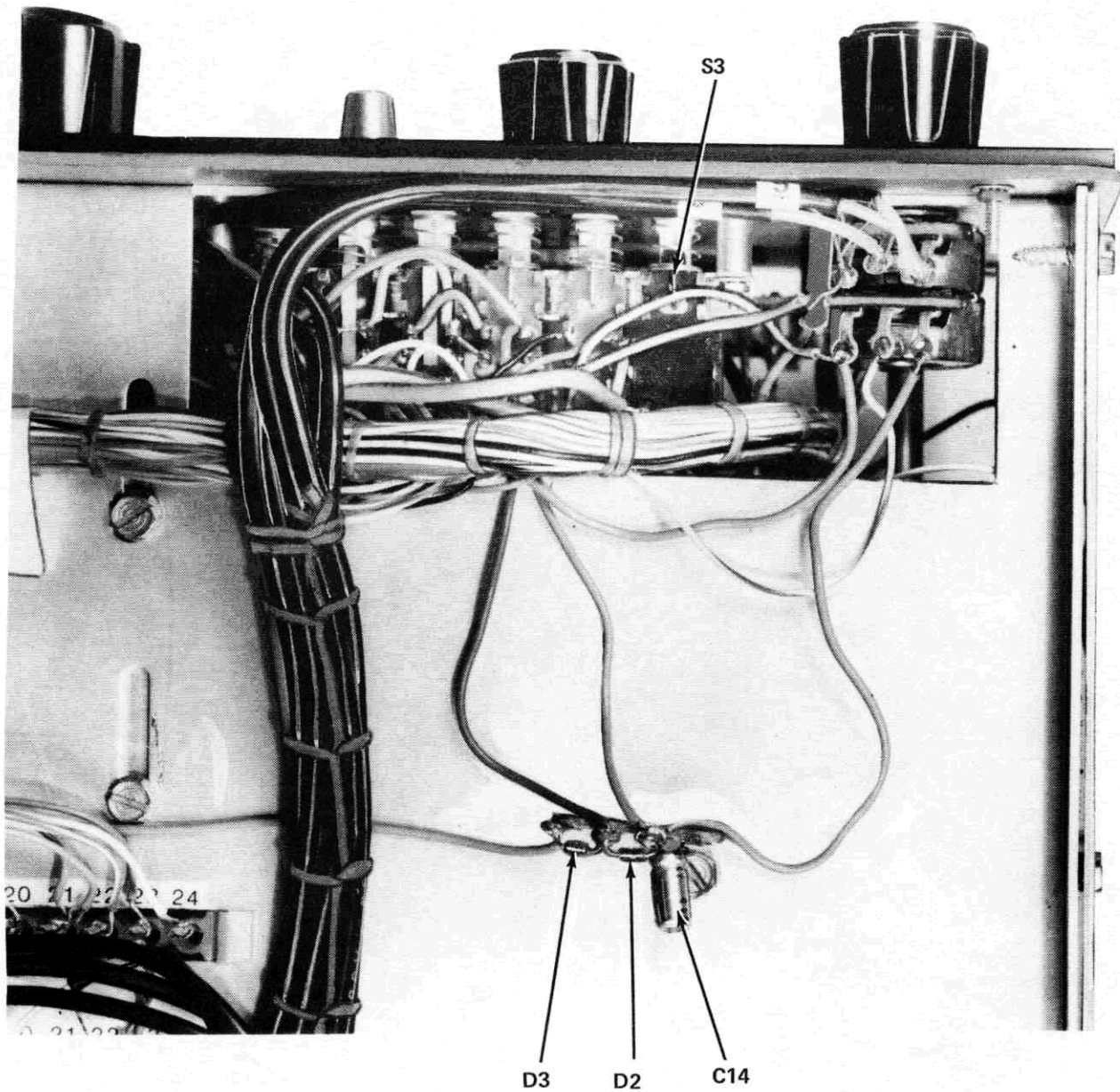

FOR PARTS REQUESTS ONLY

- Be sure to follow instructions carefully.
- Use a separate letter for all correspondence.
- Please allow 10 - 14 days for mail delivery time.

DO NOT WRITE IN THIS SPACE

INSTRUCTIONS

- Please print all information requested.
- Be sure you list the correct **HEATH** part number exactly as it appears in the parts list.
- If you wish to prepay your order, mail this card and your payment in an envelope. Be sure to include 10% (25¢ minimum, \$3.50 maximum) for insurance, shipping and handling. Michigan residents add 4% tax.
Total enclosed \$_____
- If you prefer COD shipment, check the COD box and mail this form. COD

NAME _____
 ADDRESS _____
 CITY _____
 STATE _____ ZIP _____

The information requested in the next two lines is not required when purchasing nonwarranty replacement parts, but it can help us provide you with better products in the future.

Model # _____ Invoice # _____
 Date Purchased _____ Location Purchased _____

LIST HEATH PART NUMBER	QTY.	PRICE EACH	TOTAL PRICE

TOTAL FOR PARTS	
HANDLING AND SHIPPING	
MICHIGAN RESIDENTS ADD 4% TAX	
TOTAL AMOUNT OF ORDER	

SEND TO: **HEATH COMPANY**
 BENTON HARBOR
 MICHIGAN 49022
ATTN: PARTS REPLACEMENT

Phone (Replacement parts only): 616 982-3571

FOR PARTS REQUESTS ONLY

- Be sure to follow instructions carefully.
- Use a separate letter for all correspondence.
- Please allow 10 - 14 days for mail delivery time.

DO NOT WRITE IN THIS SPACE

INSTRUCTIONS

- Please print all information requested.
- Be sure you list the correct **HEATH** part number exactly as it appears in the parts list.
- If you wish to prepay your order, mail this card and your payment in an envelope. Be sure to include 10% (25¢ minimum, \$3.50 maximum) for insurance, shipping and handling. Michigan residents add 4% tax.
Total enclosed \$_____
- If you prefer COD shipment, check the COD box and mail this form. COD

NAME _____
 ADDRESS _____
 CITY _____
 STATE _____ ZIP _____

The information requested in the next two lines is not required when purchasing nonwarranty replacement parts, but it can help us provide you with better products in the future.

Model # _____ Invoice # _____
 Date Purchased _____ Location Purchased _____

LIST HEATH PART NUMBER	QTY.	PRICE EACH	TOTAL PRICE

TOTAL FOR PARTS	
HANDLING AND SHIPPING	
MICHIGAN RESIDENTS ADD 4% TAX	
TOTAL AMOUNT OF ORDER	

SEND TO: **HEATH COMPANY**
 BENTON HARBOR
 MICHIGAN 49022
ATTN: PARTS REPLACEMENT

Phone (Replacement parts only): 616 982-3571

CUT ALONG DOTTED LINE

CUSTOMER SERVICE

REPLACEMENT PARTS

Please provide complete information when you request replacements from either the factory or Heath Electronic Centers. Be certain to include the **HEATH** part number exactly as it appears in the parts list.

ORDERING FROM THE FACTORY

Print all of the information requested on the parts order form furnished with this product and mail it to Heath. For telephone orders (parts only) dial 616 982-3571. If you are unable to locate an order form, write us a letter or card including:

- Heath part number.
- Model number.
- Date of purchase.
- Location purchased or invoice number.
- Nature of the defect.
- Your payment or authorization for COD shipment of parts not covered by warranty.

Mail letters to: Heath Company
Benton Harbor
MI 49022
Attn: Parts Replacement

Retain original parts until you receive replacements. Parts that should be returned to the factory will be listed on your packing slip.

OBTAINING REPLACEMENTS FROM HEATH ELECTRONIC CENTERS

For your convenience, "over the counter" replacement parts are available from the Heath Electronic Centers listed in your catalog. Be sure to bring in the original part and purchase invoice when you request a warranty replacement from a Heath Electronic Center.

TECHNICAL CONSULTATION

Need help with your kit? — Self-Service? — Construction? — Operation? — Call or write for assistance. you'll find our Technical Consultants eager to help with just about any technical problem except "customizing" for unique applications.

The effectiveness of our consultation service depends on the information you furnish. Be sure to tell us:

- The Model number and Series number from the blue and white label.
- The date of purchase.
- An exact description of the difficulty.
- Everything you have done in attempting to correct the problem.

Also include switch positions, connections to other units, operating procedures, voltage readings, and any other information you think might be helpful.

Please do not send parts for testing, unless this is specifically requested by our Consultants.

Hints: Telephone traffic is lightest at midweek — please be sure your Manual and notes are on hand when you call.

Heathkit Electronic Center facilities are also available for telephone or "walk-in" personal assistance.

REPAIR SERVICE

Service facilities are available, if they are needed, to repair your completed kit. (Kits that have been modified, soldered with paste flux or acid core solder, cannot be accepted for repair.)

If it is convenient, personally deliver your kit to a Heathkit Electronic Center. For warranty parts replacement, supply a copy of the invoice or sales slip.

If you prefer to ship your kit to the factory, attach a letter containing the following information directly to the unit:

- Your name and address.
- Date of purchase and invoice number.
- Copies of all correspondence relevant to the service of the kit.
- A brief description of the difficulty.
- Authorization to return your kit COD for the service and shipping charges. (This will reduce the possibility of delay.)

Check the equipment to see that all screws and parts are secured. (Do not include any wooden cabinets or color television picture tubes, as these are easily damaged in shipment. Do not include the kit Manual.) Place the equipment in a strong carton with at least **THREE INCHES** of *resilient* packing material (shredded paper, excelsior, etc.) on all sides. Use additional packing material where there are protrusions (control sticks, large knobs, etc.). If the unit weighs over 15 lbs., place this carton in another one with 3/4" of packing material between the two.

Seal the carton with reinforced gummed tape, tie it with a strong cord, and mark it "Fragile" on at least two sides. Remember, the carrier will not accept liability for shipping damage if the unit is insufficiently packed. Ship by prepaid express, United Parcel Service, or insured Parcel Post to:

Heath Company
Service Department
Benton Harbor, Michigan 49022



HEATH COMPANY • BENTON HARBOR, MICHIGAN
THE WORLD'S FINEST ELECTRONIC EQUIPMENT IN KIT FORM

LITHO IN U.S.A.